

HIGHLEAD

GC24818-1D

Post Bed Basting Machine with auto trimmer

Instruction Manual
Parts Catalog

SHANGHAI HUIGONG NO.3 SEWING MACHINE FACTORY

--- CONTENTS ---

Instruction Manual

■ CAUTIONS ON USE	1
1. Cautions on operation.	1
2. Precautions before starting operation	1
3. Precautions for operating conditions	1
4. Connection of control box	1
5. Adjustment of needle bar stop position	1
■ CAUTIONS ON USE	2
1. Lubrication (1)	2
2. Lubrication (2)	2
■ OPERATION	3
1. Attaching the needle	3
2. Winding the bobbin thread	3
3. Threading the machine	3
4. Setting of bobbin	3
5. Leading out the bobbin thread	3
6. Thread tension	3
7. Bobbin thread tension adjustment	4
8. Needle thread tension adjustment	4
9. Adjustment of thread tension regulator	5
10. Presser foot pressure adjustment	5
11. Adjustment of presser foot height	5
12. Timing of hook and needle	5
13. Timing between hook motion and take-up lever motion	6
14. Timing between hook motion and opener motion	7
■ ADJUSTMENT OF THREAD TRIMMER	7
1. Driving knife adjustment	7
2. Adjusting the fixed knife position and bobbin thread clamping.	7
3. Adjustment of trimmer cam	8

Parts Catalog

A. ARM BED MECHANISM	9
B. THREAD TENSION REGULATOR MECHANISM	11
C. NEEDLE BAR AND THREAD TAKE-UP MECHANISM	13
D. NEEDLE BAR & PRESSER FOOT MECHANISM	15
E. HOOK SADDLE MECHANISM	17
F. KNIFE MECHANISM	20
G. LOWER SHAFT & OIL LUBRICATION MECHANISM	22
H. ACCESSORIES	24

■ CAUTIONS ON USE

1. Cautions on operation

1) When the power is turned on and off, keep your foot away from the pedal. Note that the needle goes up to the UP position when the power switch is turned on.

2) Note that braking does not work if the power is turned off, or power failure takes place, during machine operation.

3) Since dust or other foreign matter entering into the control box may cause malfunction or trouble, be sure to keep control box cover closed during operation.

4) Do not use a multimeter to check the control circuit. Otherwise, semiconductors in the control circuit might be damaged by voltage from the multimeter.

2. Precautions before starting operation:

1) Never operate the machine before filling the machine's oil pan.

2) When a new sewing machine is first turned on, verify the rotational direction of the pulley with the power on.

3) Verify the voltage and phase (single or three) with those given on the machine nameplate.

3. Precautions for operating conditions:

1) Avoid using the machine at abnormally high temperatures (35°C or higher) or low temperatures (5°C or lower) .

2) Avoid using the machine in dusty conditions.

4. Connection of control box

The control box should be connected as shown to the right.

Note: (1) Be sure to turn the power switch off for safety before connecting or disconnecting the connectors.

(2) The combination of the machine heads with the motor control panels are specified below. Use special care for the correct combination when replacing the machine head or motor control panel.

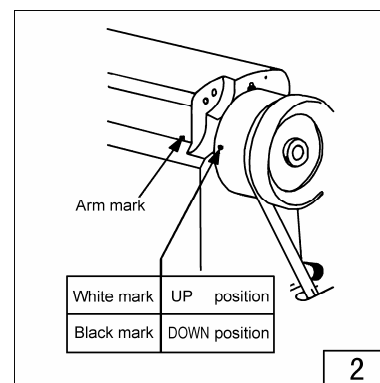
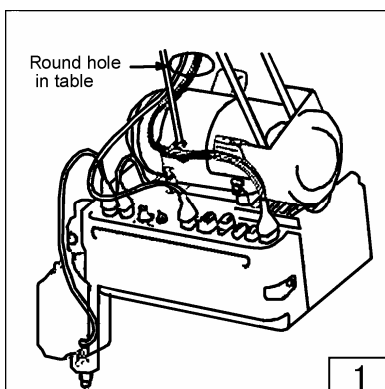

5. Adjustment of needle bar stop position

1) Adjust of "UP" position: When the pedal is kicked down by heel, the machine stops at "UP" position.

If the marks deviate larger than 3 mm, adjust as follows.

- (1) Disconnect the plug (12 pins) of cable from the machine head.
- (2) Run the machine and stop at “UP” position.
- (3) While holding the pulley, insert the “adjusting tool” in the hole “A”, then remove the tool.

2) Adjust of “Down” position: When the pedal is “Neutral” the machine stops at “Down” position. If the marks deviate large than 5 mm, adjust as follows.

- (1) Disconnect the plug (12 pins) of cable from the machine head.
- (2) Run the machine and stop at “Down” position.
- (3) While holding the pulley, insert the “adjusting tool” in the hole “B”, then remove the tool.

3) Confirm the stop operation, then set the plug (12 pins) coming from the machine head into the receptacle.

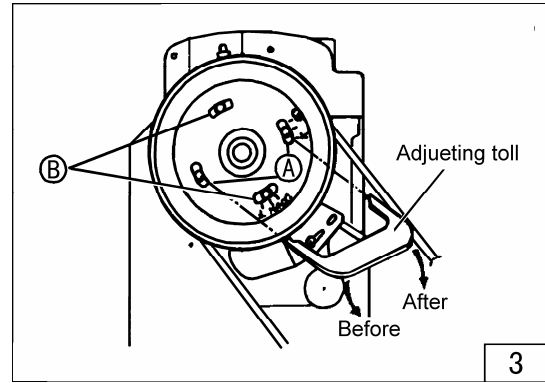

■ CAUTIONS ON USE:

1. Lubrication(1)(Fig.4)

Pour oil up to position “H” of the oil tank.

During operation, check the oil level periodically, and in cases where the oil level is below position “L”, replenish the oil supply up to position “H”.

Use white spindle oil.

2.Lubrication (2)(Fig.5)

When a new sewing machine is used for the first time, or sewing machine left out of use for a long time is used again, replenish a suitable amount of oil to the portions indicated by arrow in the fig.

Note: Lubricate the Hook Base everyday.

- 1-2 drops
- 3-4 drops

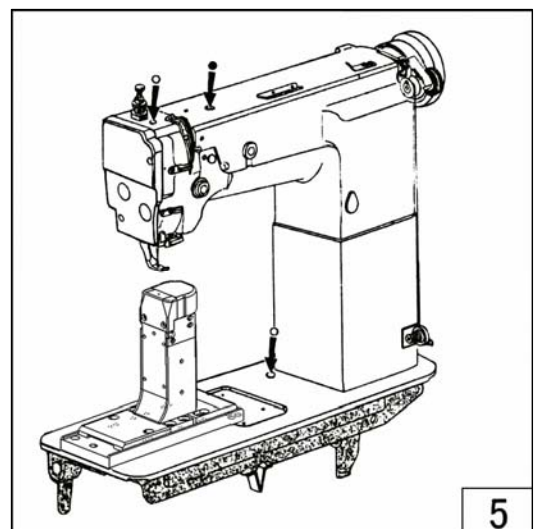
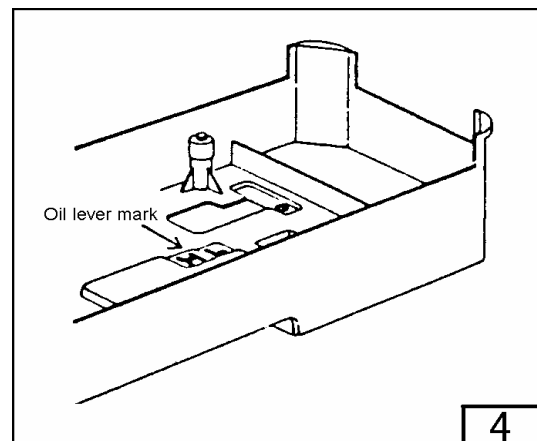

■ OPERATION

1.Attaching the needle(Fig.7)

- 1) For needle, use “Mt×190”
- 2) Determine the needle gauge for thickness If thread used.
- 3) Loosen the needle clamp screw.
- 4) Hold the needle with the prime groove turned to the front and put it into the needle socket until it stops.
- 5) Tighten the needle clamp screw.

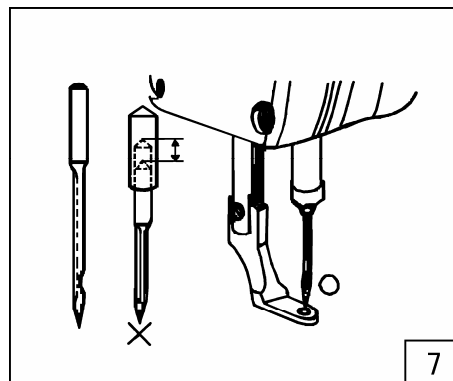

2.Winding the bobbin thread(Fig.8)

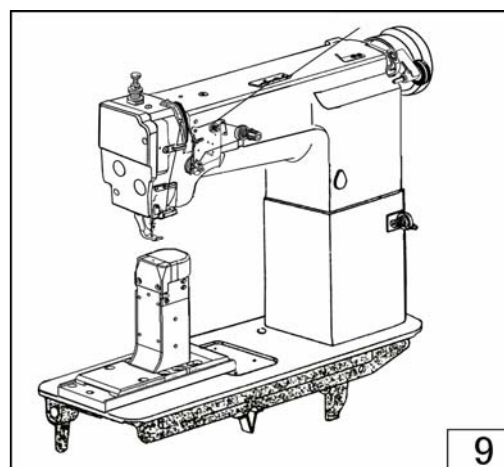
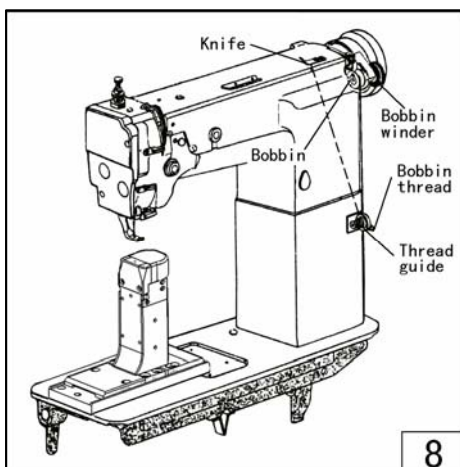

3.Threading the machine(Fig.9)

The needle should be threaded in the order numbered in the right figure.

4.Setting of bobbin (Fig.10)

- 1) Raise flap 1 and remove the empty bobbin.
- 2) Insert bobbin 2 in such a way that when the thread is unwound from it moves in the opposite direction to the gripper.
- 3) Pass the thread through slit 5 and below spring 6, pass the thread through slit 3 and pull about 3 cm through.
- 4) Close flap 1 and pass the thread through the flap's guide 4.

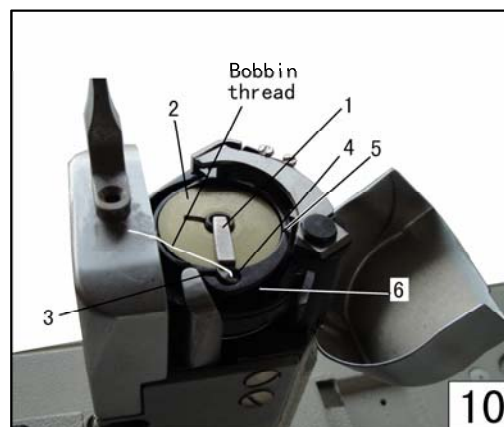

5.Leading out the bobbin thread(Fig. 11)

Pick up the end of needle thread by left hand and lightly press down the pedal by toe to run the machine one turn. When the needle thread is pulled up, the bobbin thread will be drawn out as shown in the right figure.

6.Thread tension (Fig.12)

7. Bobbin thread tension adjustment(Fig.13)

The lower-thread tension should be set in accordance with the type of seam required. Adjust the tension with screw 1. (Fig.13)

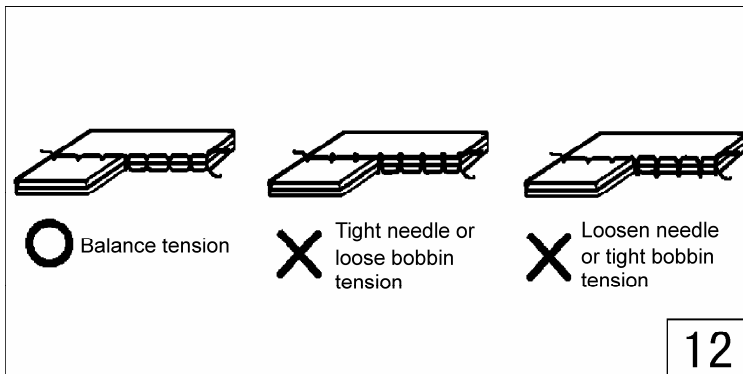

8. Needle thread tension adjustment

The needle thread tension can be adjusted by changing pressure of the tension disk, and force and stroke of the thread take-up spring.

1) Tension disk pressure adjustment (Fig.14)

(1) In most cases, thread tension can be properly adjusted only by changing tightness of the tension regulator thumb nut.

(2) To increase pressure, turn the nut clockwise.

(3) To decrease pressure, turn the nut counter-clockwise.

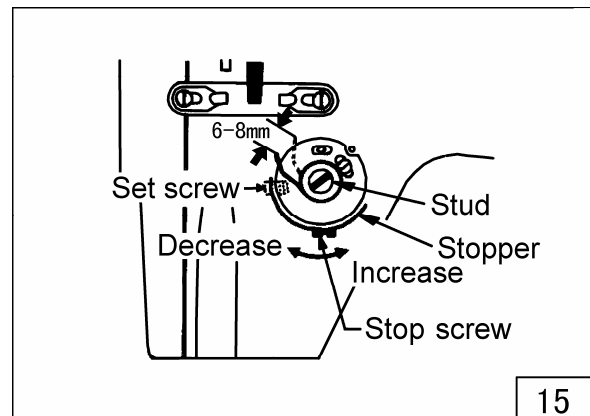
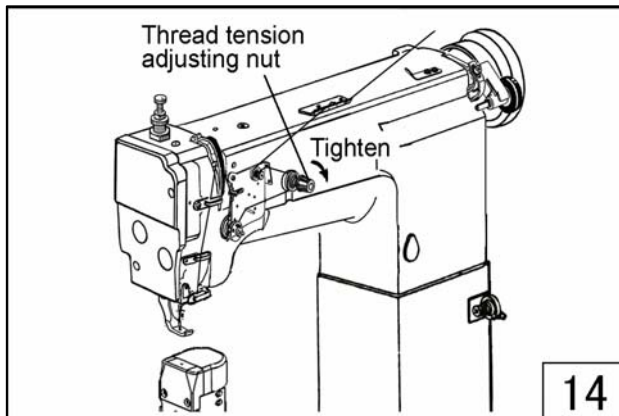

2) Thread take-up spring force/stroke adjustment (Fig.15)

Apply a screwdriver to the thread take-up spring stud and turn the stud. Spring force increases when the screwdriver is turned counter-clockwise, and decreases when turned clockwise. If the stud is tight, remove the face plate and loosen the screw of tension regulator slightly.

3) Thread take-up spring force/stroke adjustment (Fig.15)

Loosen the stop screw, adjusting the stopper block, After the adjustment, be sure to tighten the set screw. The standard stroke of thread take-up spring is from 6mm to 8mm.

9.Adjustment of thread tension regulator (Fig. 16)

1) Adjustment of thread tension regulator setting position. The standard gap is about 0.5mm when the tension release cam salience is in contact with the tension release pin. To adjust, loosen screw A and change position of the thread tension regulator properly.

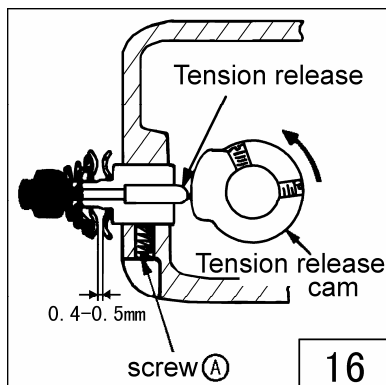

2) Tension release timing adjustment. The tension release cam should be set so that the tension release disks come to close at the time the needle plunges into the throat plate.

10.Presser foot pressure adjustment (picture 17)

Loosen the pressure adjusting screw lock nut and turn the pressure adjusting screw ③. Turn the screw clockwise to increase the pressure. Turn the screw counter-clockwise to decrease the pressure.

Note: Do not change setting of screw ④. If the screw is too tight, clapping noise may occur during operation.

11.Adjustment of presser foot height (picture 17)

1) Height of presser foot

The standard height of the presser foot at its lowest position is 1.0 mm measured between the presser foot bottom surface and the throat plate top surface (see the detail of part "A").

To adjust the height of the presser foot, loosen the set screw ② used to secure the presser bar guide bracket and vertically move the presser bar.

2) Stroke of presser foot

loosen screw ① and adjust position of presser bar lifting bracket so that the presser foot starts going up when the needle point reaches 0.5mm-1.0mm above the presser foot bottom surface.(When this adjustment is made, the height of the presser foot at stop of the machine is about 26.5mm over the throat plate.)

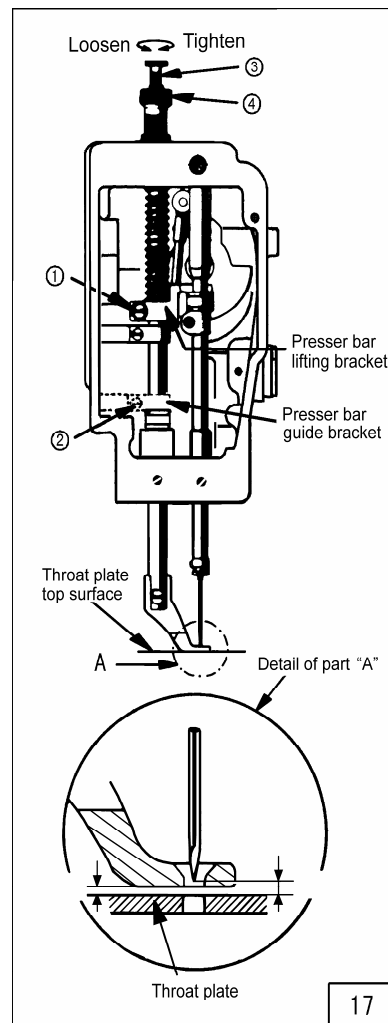

12.Timing of hook and needle(Fig.18)

1) When the needle is at 2.2mm above its lowest position, the hook

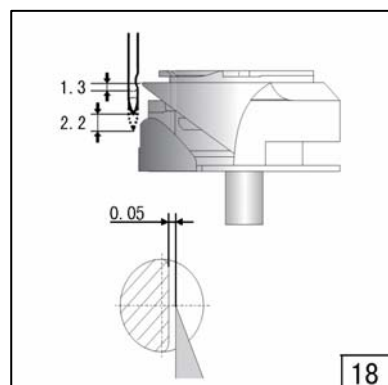

and the needle should be located as described below.

- **The upper edge of needle eye is 1.3mm below the hook tip.**
- **The clearance between the hook tip and the needle side surface is 0.05mm.**

2) The relative positions of the hook and the needle can be adjusted as described below.

*The adjustment is easier when the presser foot and the throat plate are previously removed.

- **Adjustment of hook tip position (Fig.19.Fig.20.Fig.21)**

a. Lean outward the machine head. Loosen three hook shaft gear screws.

b. Rotate the balance wheel by hand to position the needle to 2.2mm above the needle DOWN position.

c. Rotate the hook by hand to align the hook tip with the center of the needle.

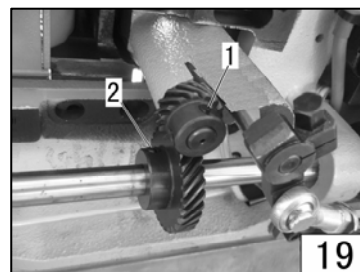

d. Adjust the lateral position of the hook saddle so that the clearance between the hook tip and the needle side surface is 0.05mm. To adjust, loosen screws ①, ② and ③.

Note: Use care not to loosen set screw ③ excessively, and not to disengage the hook shaft gear (small) from the gear (large).

e. Tighten the loosened screws in the following order:

3) Lightly press the gear (large) against the side wall of hook saddle and tighten set screw ③ first.

4) Check the clearance between the needle and the hook and then tighten screw ①.

5) Finally tighten screw ②.

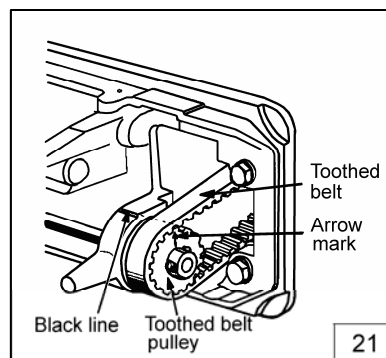
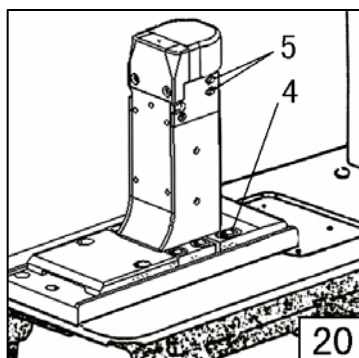

13. Timing between hook motion and take-up lever motion(Fig.22)

When the toothed belt is removed for replacement, the timing between the hook motion and the take-up lever motion should be adjusted as follow:

1) Turn the balance wheel by land to locate the take-up lever to its highest position.

2) Lean outward the machine head to make sure the arrow mark (timing mark) on the toothed belt pulley meets the black line put on the bearing bracket.

3) If the arrow mark is not in line with the black line, remove the toothed belt and install again so that the two marks are in line, as shown in the right figure.

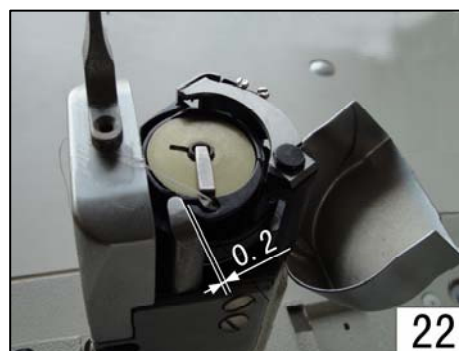

14. Timing between hook motion and opener motion(Fig.21)

1) Rotate the balance wheel by hand to locate the opener holder to the farthest position away from the throat plate.

2) Make sure the clearance between the portion ① of bobbin case and the opener is about 0.2mm as shown in the right figure.

3) If the clearance is too large or small, loosen opener screw ② and adjust position of the opener.

■ ADJUSTMENT OF THREAD TRIMMER

1. Driving knife adjustment

In resting position the rear edge of the driving knife should be flush with the front edge of the counter-knife.

The fixed knife should abut on the thread pulling knife along its total width.

The pivoting driving knife should abut on the fixed knife after approx.1/3 of its width.

The driving knife must not collide with the bobbin case.

The clearance between the lower blade edge of the driving knife a and the lower surface of the inner rotary hook b should be 0.3-0.4mm.

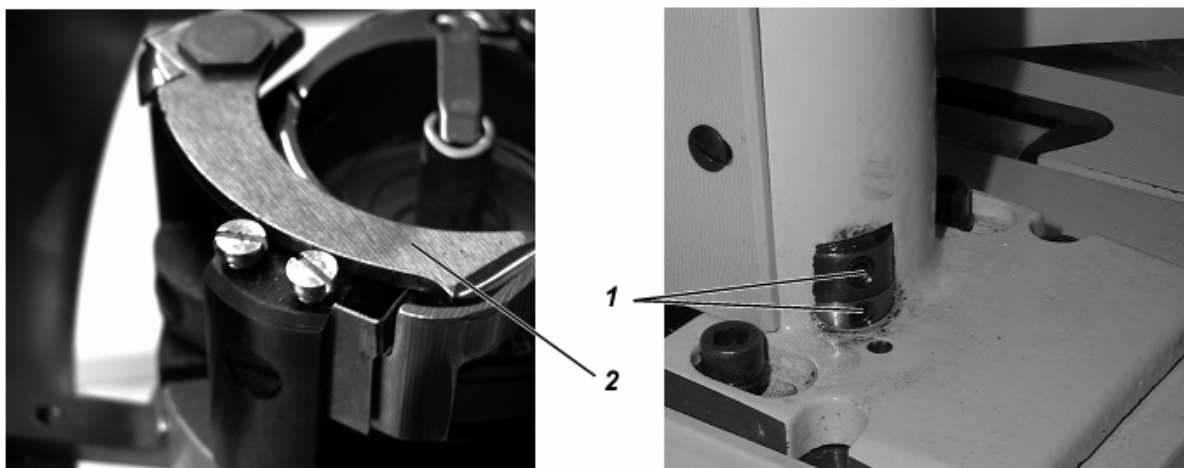

Checking: Loosen two screws 1 for adjusting the resting position of the driving knife and adjust the knife according to the standard, then tighten screws 1.

Attention:

Check the axial clearance of the knife shaft when tightening the screws 1. The driving knife must be easily movable and the axial clearance as low as possible.

2. Adjusting the fixed knife position and bobbin thread clamping.

Checking:

The clamping spring 5 has the function to hold the cut bobbin thread in order to avoid skipped stitches at the seam beginning.

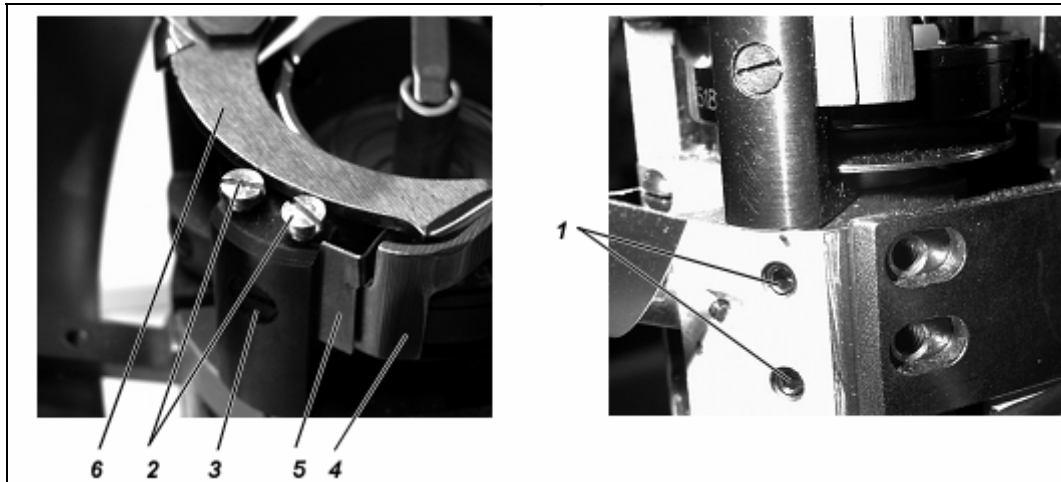

Fixed knife 4 and driving knife 6 must be in parallel position standing under a slight cutting pressure.

Parallel position correction

Loosen screw 3 slightly for adjusting the parallel position of thread pulling knife 6 and counter-knife 4, then change counter-knife 4 by setting the screws 2 in such a way that the edges of thread pulling knife and counter-knife are in parallel position. Tighten screw 3 at last.

Cutting pressure adjustment

The knives should guarantee a safe cut at the lowest possible pressure of the counter-knife against the thread pulling knife. This is normally the case when the edge of the counter-knife just touches the thread pulling knife with a knife overlapping of 1/3.

Loosen screws 1, then turn counter-knife support in such a way that the condition is fulfilled, at last, tighten screws 1.

3.Adjustment of trimmer cam (Fig.24)

- 1) Rotate the balance wheel to lower the needle to the DOWN position
- 2) While keeping the DOWN position, press the cam follower crank to enter the roller into the trimmer cam groove.

3) Adjust the trimmer cam so that the movable knife starts moving when the balance wheel is turned by hand and the green mark point on the balance wheel meets the black point on the arm.

To adjust, loosen two trimmer cam screws A.

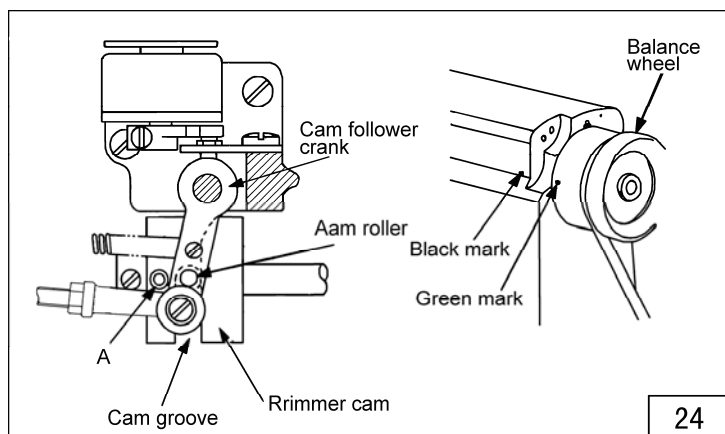

A.ARM BED MECHANISM

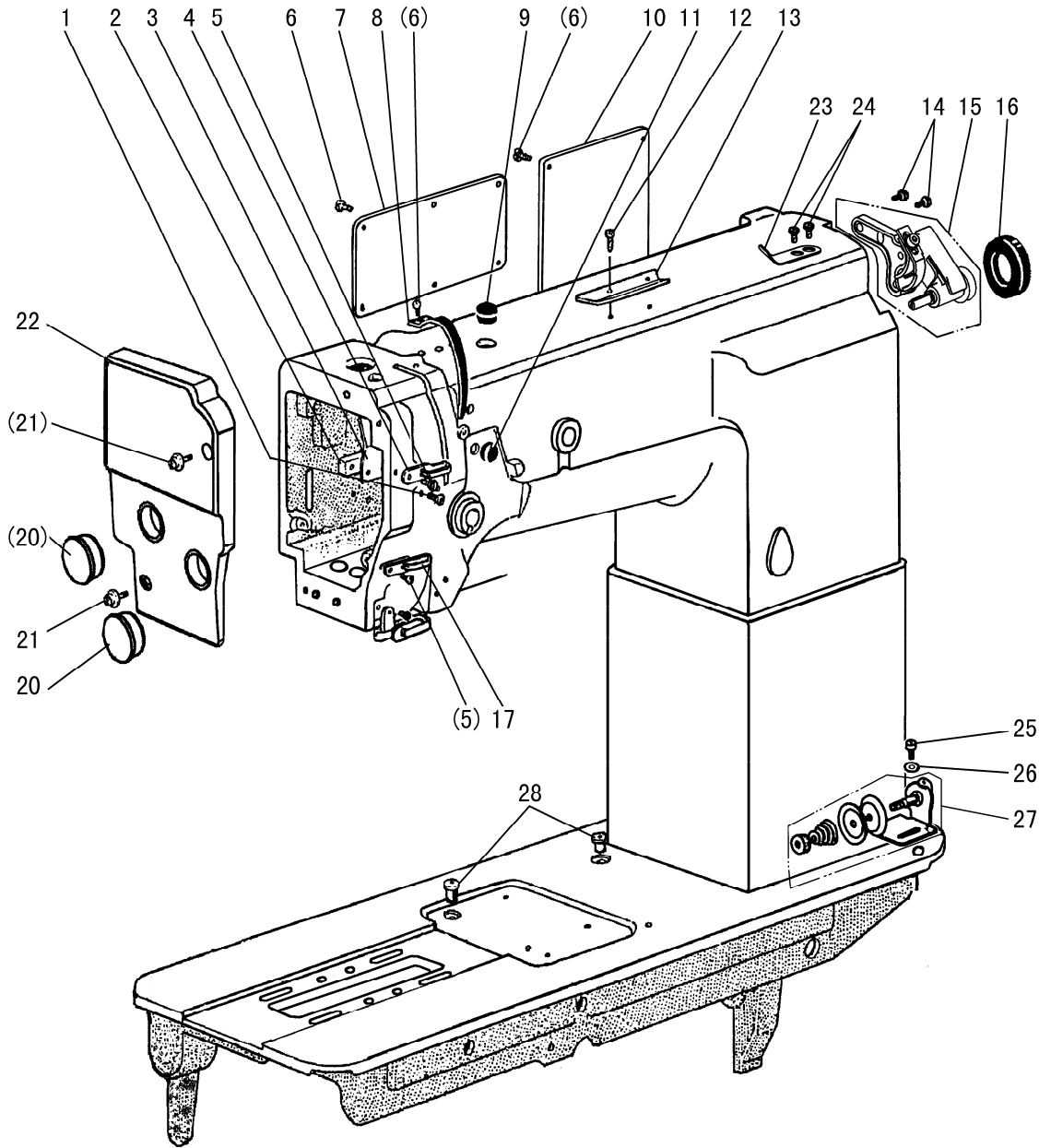

A.ARM BED MECHANISM

Fig. No.	Part No.	Description	Pcs.	Remarks
A01	H3000D2160	Screw	2	
A02	H2400B2060	Spacer	1	GB/T 5782 M12×30
A03	H3200B2060	Oil guide plate	1	GB/T 70.1 M12×30
A04	H3200B2070	Thread guide	1	GB/T 117 6×28
A05	H2400B2080	Screw	3	
A06	HA300B2170	Screw	11	
A07	H3200B2030	Arm side cover (left)	1	
A08	H3200B2050	Thread take-up cover	1	
A09	H2400J2010	Oil cap	1	φ 13
A10	H3200B2040	Arm side cover (right)	1	
A11	H2000B2010	Rubber plug	1	φ 13
A12	HA700B2060	Screw	2	
A13	H2400B2100	Thread guide	1	
A14	HA100E2150	Screw	2	SM11/64(40)×10
A15	HH415B7101	Bobbin winder complete	1	
A16	H6658B8001	Rubber ring	1	φ 35
A17	H3200B2080	Thread guide	2	
A20	HA307B0673	Rubber plug	2	φ 19
A21	HA300B2160	Screw	2	
A22	H3200B2020	Face plate	1	
A23	H6756B8001	Thread cutter	1	
A24	H6762B8001	Screw	2	SM9/64(40)×4.5
A25	HA100E2150	Screw	1	SM11/64(40)×10
A26	HA100B2070	Washer	1	φ 4.5×φ 8×1
A27	HH427B7101	Thread guide complete	1	
A28	H2000M0090	Cap	2	

B.THREAD TENSION REGULATOR MECHANISM

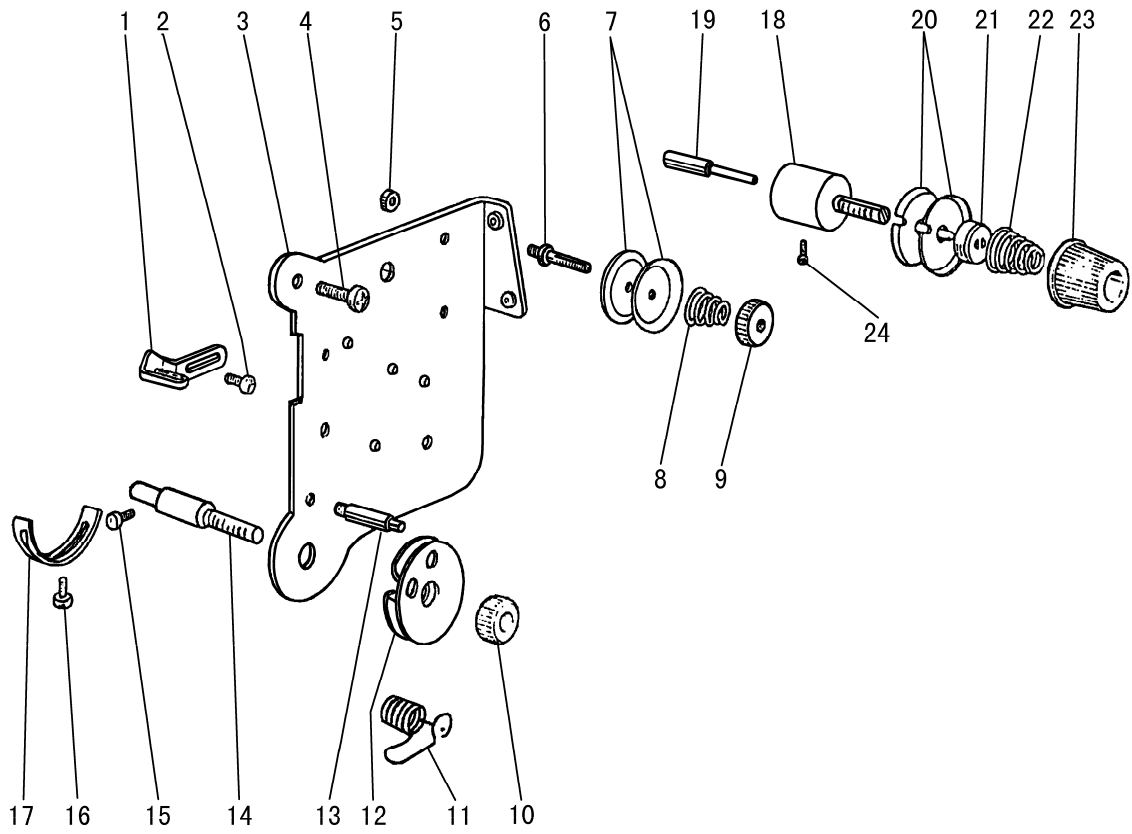

B.THREAD TENSION REGULATOR MECHANISM

Fig. No.	Part No.	Description	Pcs.	Remarks
B01	H3221B0687	Thread guide	1	
B02	HA106B0676	Screw	1	SM9/64 (40) × 6
B03	H3221B6820	Mounting plate	1	
B04	HA300C2030	Screw	2	SM11/64 (40) × 8
B05	H3221B6810	Nut	2	SM11/64 (40) × 3
B06	H3221B0683	Thread tension stud	1	SM11/64 (40) × 14
B07	HA112B0693	Thread tension disc	2	
B08	H3221B0684	Spring	1	
B09	HA710B0671	Thumb nut	1	
B10	H2504C0658	Thumb nut	1	
B11	H32481B221	Thread Take-up spring	1	
B12	H32481BD21	Plate complete	1	
B13	H4804C8001	Screw	1	SM9/64 (40) × 22
B14	H2504C0652	Thread tension stud	1	
B15	H2004J0067	Screw	1	SM9/64 (40) × 7
B16	H3200B2100	Screw	1	SM9/64 (40) × 6.5
B17	H3221B6819	Stopper	1	
B18	HH406C8001	Thread tension stud	1	
B19	HH407C8001	Thread releasing pin	1	
B20	HA310B0705	Thread tension disc	2	
B21	HA310B0702	Tension releasing plate	1	
B22	HA607B0068	Spring	1	
B23	HA310B0701	Thumb nut	1	
B24	HA3411D308	Screw	1	

C.NEEDLE BAR AND THREAD TAKE-UP MECHANISM

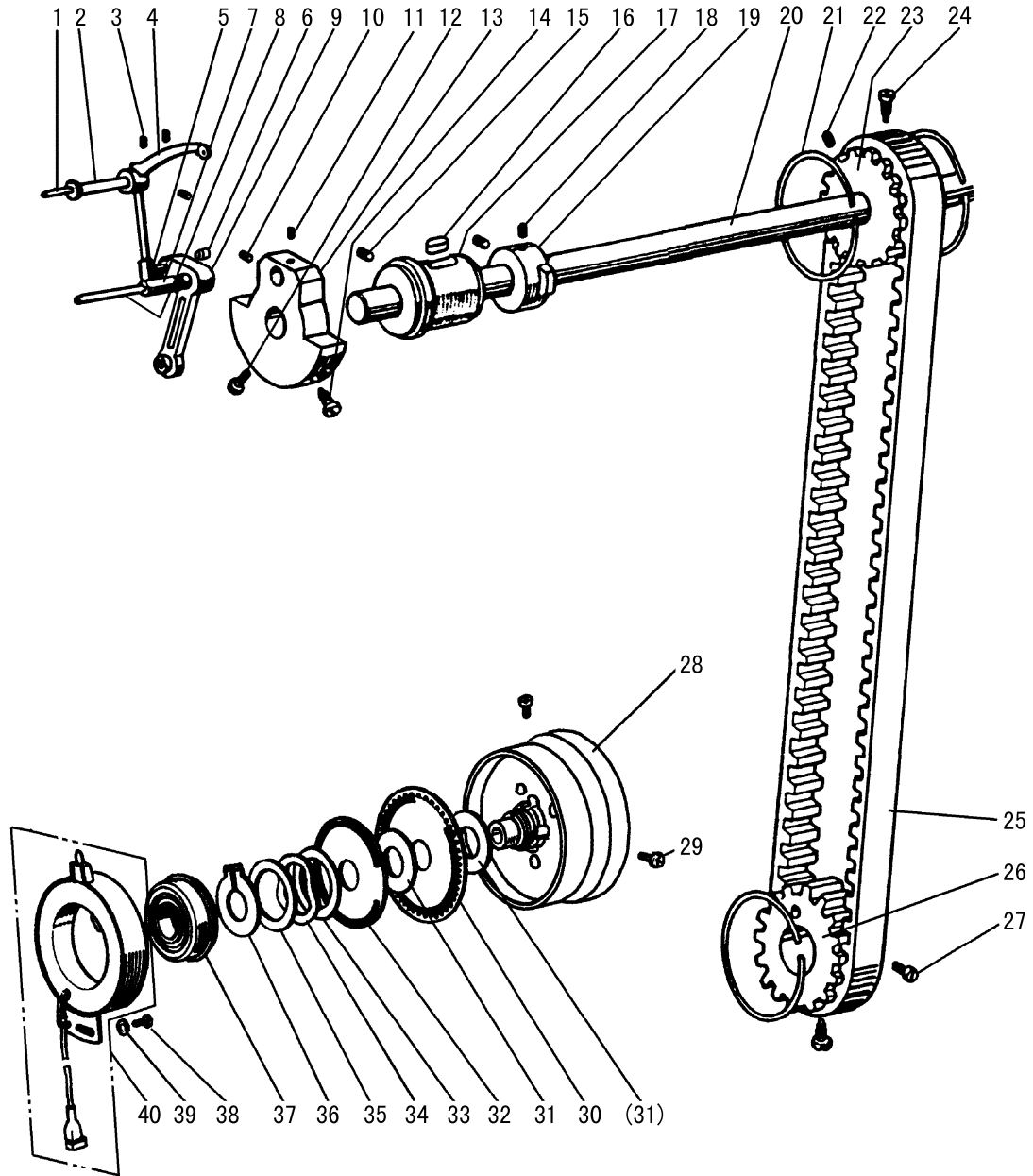

C.NEEDLE BAR AND THREAD TAKE-UP MECHANISM

Fig. No.	Part No.	Description	Pcs.	Remarks
C01	H2405D1122	Oil wick	1	2. 5×240
C02	H32422C108	Thread Take-up guide bracket pin	1	
C03	HA110D0672	Screw	3	SM15/64 (28) × 12
C04	H2405D1111	Thread Take-up lever	1	
C05	H2405D1112	Thread Take-up slide block	1	
C06	H24211D305	Plug	1	
C07	H2405D0662	Thread take-up crank pin	1	
C08	H24211D405	Oil wick	1	
C09	H32111D704	Needle bar connecting link	1	
C10	HA108C0663	Screw	1	SM1/4 (40) × 7
C11	HA105D0662	Screw	1	SM1/4 (40) × 4
C12	HA100C2070	Screw	1	SM9/32 (28) × 10
C13	HH405D7101	Arm shaft needle bar crank complete	1	
C14	HA100C2060	Screw	1	SM9/32 (28) × 13
C15	H2405D0664	Screw	1	SM15/64 (28) × 14
C16	H32111B104	Felt	1	
C17	H3204B0011	Arm shaft bushing left (complete)	1	
C18	HA3411D308	Screw	2	
C19	HH404D8001	Thread releasing cam	1	
C20	H3204C0651	Arm shaft	1	
C21	H3205C0661	Spring flange	2	
C22	HA113F0684	Screw	1	SM15/64 (28) × 8. 5
C23	H3207C0671	Pulley	1	
C24	HA100F2130	Screw	1	SM15/64 (28) × 6. 7
C25	H6304C8001	Cog belt	1	
C26	H3205C1021	Pulley	1	
C27	HA104F0654	Screw	2	
C28	H4931L8001	Machine pulley	1	
C29	HA110D0672	Screw	2	
C30	H4930L8001	Speed command disk F11 (down)	1	
C31	HA700R0030	Spacer A	2	
C32	H4928L8001	Speed command disk F20 (up)	1	
C33	HA700R0040	Spacer B	1	
C34	HA700R0050	Spacer	1	
C35	HA700R0060	Stopper	1	
C36	H007009300	Retaining ring C-type	1	
C37	H3205J0662	Ball bearing	1	
C38	HA300C2030	Screw	1	
C39	HA703R0067	Washer	1	
C40	HA703R0065	Detector bracket	1	

D.NEEDLE BAR & PRESSER FOOT MECHANISM

Fig. No.	Part No.	Description	Pcs.	Remarks
D01	H2405D0664	Screw	3	SM15/64 (28) × 14
D02	HD417D8001	Bushing	1	
D03	HH405E8001	Washer	4	
D04	HH406E8001	Rubber ring	2	
D05	H32111D504	Needle bar connecting	1	
D06	H32111D604	Screw	1	SM9/64 (40) × 8.5
D07	HD415D8001	Crank guide	1	
D08	HA100C2190	Screw	2	SM11/64 (40) × 8
D09	HD416D8001	Bell crank guide	1	
D10	HH417E8001	Needle bar	1	
D11	HD413D8001	Bushing	1	
D12	H6204D8001	Needle clamp	1	
D13	HA500C2030	Needle bar thread guide	1	
D14	HA100C2170	Screw	1	SM1/8 (44) × 4.5
D15	JZMt1900G16	Needle	1	MT × 190 16#
D16	HH407E8001	Lifting presser	1	
D17	H3200E2020	Screw	1	1/8 (44) × 9
D18	HH408E8001	Bushing	1	
D19	HH409E8001	Presser bar position guide bracket	1	
D20	HA300C2030	Screw	2	SM11/64 (40) × 8
D21	HH411E8001	Bracket	1	
D22	HH412E8001	Lever spring	1	
D23	HH413E8001	Presser bar	1	
D24	HH414E8001	Spring	1	
D25	HA117H0692	Nut	1	SM1/2 × 28
D26	H2400G0140	Screw	1	SM1/2 (28) × 55
D27	H2400G0160	Nut	1	SM11/64 (40)
D28	H2400G0150	Screw	1	SM11/64 (40) × 48
D29	HA70400657	Rubber plug	1	
D30	HE016L8001	Felt	1	
D31	HH416E8001	Pin	1	

E.HOOK SADDLE MECHANISM

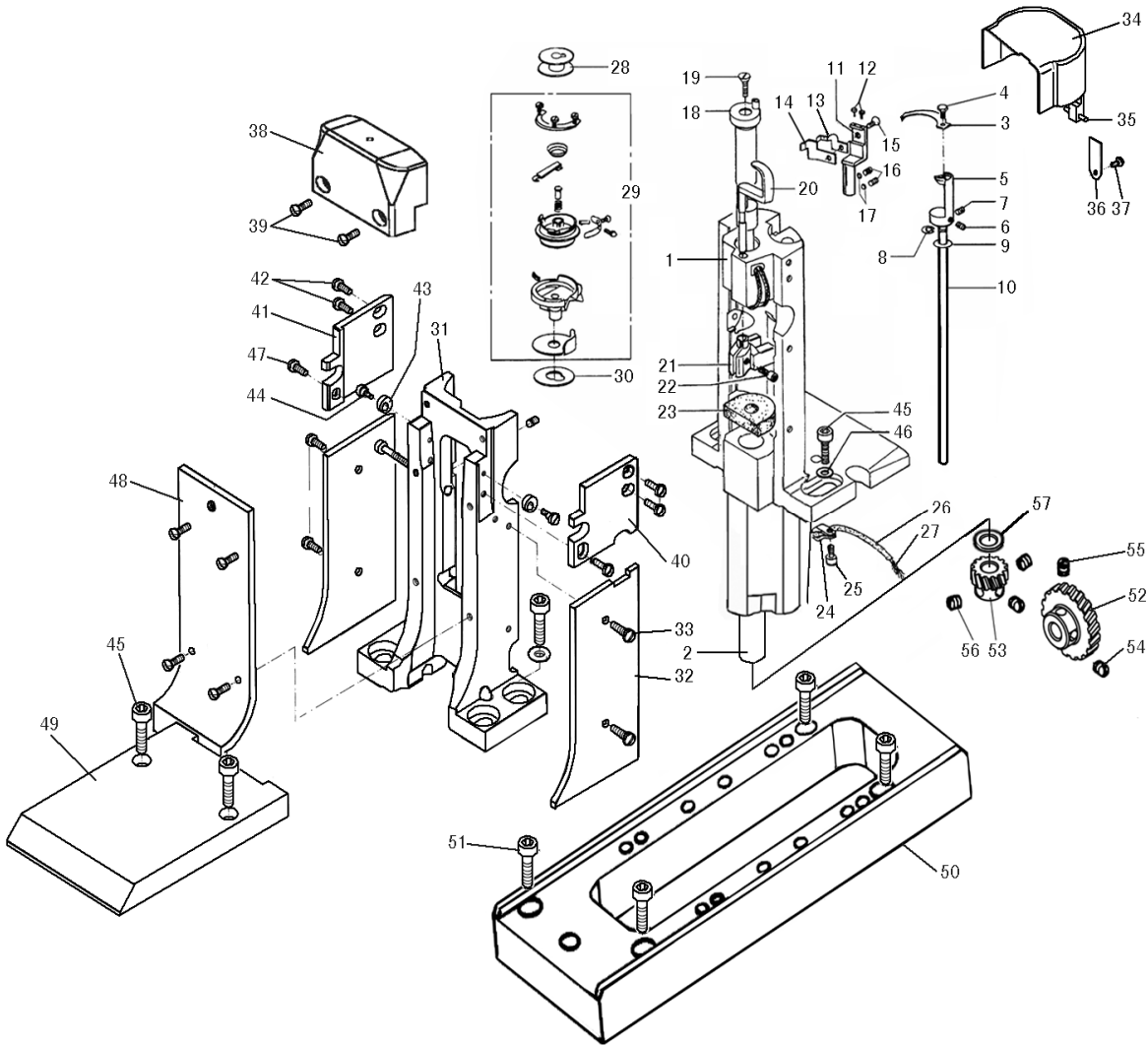

E.HOOK SADDLE MECHANISM

Fig. No.	Part No.	Description	Pcs.	Remarks
E01	HG106J8001	Hook column	1	41G09-003P01
E02	HH30I68001	Bushing	1	
E03	HG108J8001	Knife	1	
E04	HG109J8001	Hexagonal screw	1	
E05	HG110J8001	Knife bearer cpl	1	
E06	HG111J8001	Screw	1	
E07	HG112J8001	Screw	1	
E08	H007013060	Lock washer	1	
E09	HF945I8001	Washer	1	
E10	HH30I78001	Knife shaft	1	
E11	HG119J8001	Knife bearer	1	
E12	H401020050	Screw	2	
E13	HG121J8001	Spring	1	
E14	HG122J8001	Couter knife	1	
E15	H403025040	Screw	1	M2. 5×4
E16	H431040050	Screw	2	
E17	HG123J8001	Pressure pin	2	
E18	HH30I87101	Hook shaft	1	
E19	HG127J8001	Screw	1	
E20	HG128J8001	Lever	1	
E21	HG131J8001	Lifter fork	1	
E22	H415040080	Screw	1	
E23	HG133J8001	Oil cushion	1	
E24	H6732K8001	Clip	1	
E25	H402040060	Screw	1	
E26	HG140J8001	Oil pipe	1	φ 4×340
E27	HG141J8001	Oil wick	1	
E28	HG187J8001	Bobbin	1	
E29	HG145J7101	Hook complete	1	
E30	HG146J8001	Washer	1	
E31	HG90J78001	Feed bar set bracket	1	
E32	HG90J88001	Cover plate	2	
E33	HG163J8001	Screw	8	
E34	HG164J7101	Cover	1	
E35	H605020180	Pin	1	
E36	HG171J8001	Spring	1	
E37	H401030060	Screw	1	
E38	HB32F53081	Needle plate	1	
E39	HD726G8001	Screw	2	
E40	HG91J48001	Adjust cover 1	1	
E41	HG91J58001	Adjust cover 2	1	
E42	HG163J8001	Screw	4	
E43	HG181J8001	Plate holder	2	

E.HOOK SADDLE MECHANISM

Fig. No.	Part No.	Description	Pcs.	Remarks
E44	HG182J8001	Screw	2	
E45	H415060160	Screw	8	
E46	H005001060	Washer	4	
E47	HG191J8001	Screw	2	
E48	HG91J88001	Cover plate	1	
E49	HG91J98001	Cover plate	1	
E50	HH31I28001	Plate	1	
E51	H415060200	Screw	4	
E52	H32142I104	Gear(large)	1	
E53	H32142I204	Gear (small)	1	
E54	H3204I6510	Set screw	1	
E55	HA307C0662	Set screw	1	
E56	HA105D0662	Set screw	3	
E57	H3100E2220	Washer	1	

F.KNIFE MECHANISM

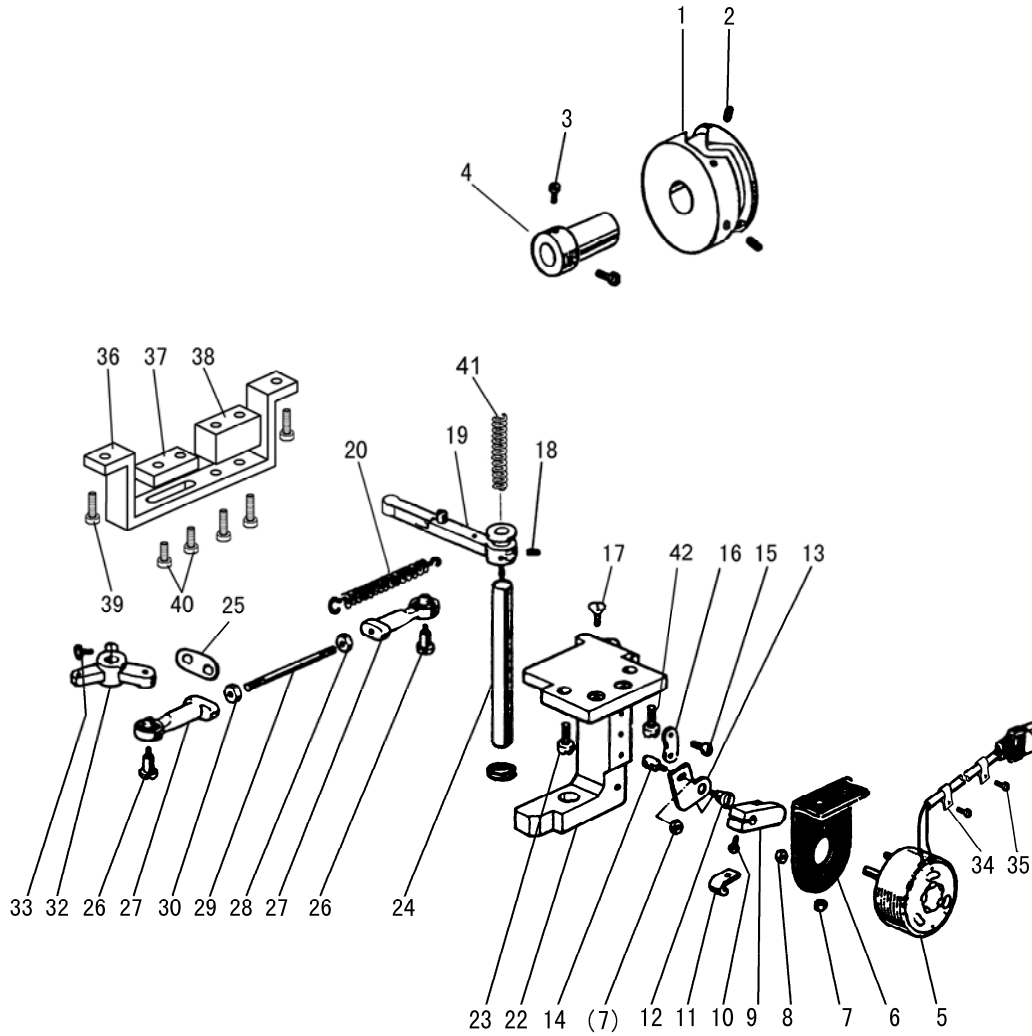

F.KNIFE MECHANISM

Fig. No.	Part No.	Description	Pcs.	Remarks
F01	HH31M68001	Cam	1	
F02	HA710E0692	Screw	2	SM1/4 (40) × 9.5
F03	HA113F0684	Screw	2	SM15/64 (28) × 8.5
F04	H6904J8001	Bushing	1	
F05	H4979K8002		1	
F06	H4977K8001	Mounting plate	1	
F07	H003008050	Nut	2	GB/T6172.1 M5
F08	H4951K8001	Nut	1	SM11/64 (40)
F09	H4974K8001	Arm	1	
F10	HA111G0683	Screw	1	SM11/64 (40) × 12
F11	H4981K8001	Holder	1	
F12	H4972K8001	Screw	1	SM11/64 (40) × 6.8
F13	H4971K8001	Lever	1	
F14	H4970K8001	Screw	1	SM11/64 (40) × 6
F15	H4967K8001	Screw	3	SM11/64 (40) × 7
F16	H4966K8001	Stopper	1	
F17	H411050160	Screw	2	GB/T819.1 M5×16
F18	H3205G1114	Screw	2	M5×5
F19	HH30M87101	Vibrating crank complete	1	
F20	H6017H8001	Spring	1	
F22	H4965K8001	Set plate	1	
F23	H2012N0652	Screw	1	SM1/4 (24) × 16
F24	H4963K8001	Shaft	1	
F25	HH32M18001	Hanging plate	1	1
F26	H4936K8001	Screw	2	M5 (0.5) × 8.5
F27	H3405D0663	Ball joint (right)	2	
F28	H003002050	Nut (right)	1	GB/T6170 M5
F29	H3405D0661	Bolt	1	
F30	H4940K8001	Nut (left)	1	M5 (left)
F32	HH30M58001	Arm	1	
F33	H4913K8001	Bolt	1	SM15/64 (28) × 12.5
F34	H4980K8001	Holder	2	
F35	HA300B2170	Screw	2	SM11/64 (40) × 8
F36	HH31M18001	Mounting plate	1	
F37	HH31M28001	Guide plate	1	
F38	HH31M38001	Limiting stopper	1	
F39	H415050100	Screw	2	
F40	H415050140	Screw	4	
F41	H4945K8001	Spring	1	
F42	H4983K8001	Screw	1	

G.LOWER SHAFT & OIL LUBRICATION MECHANISM

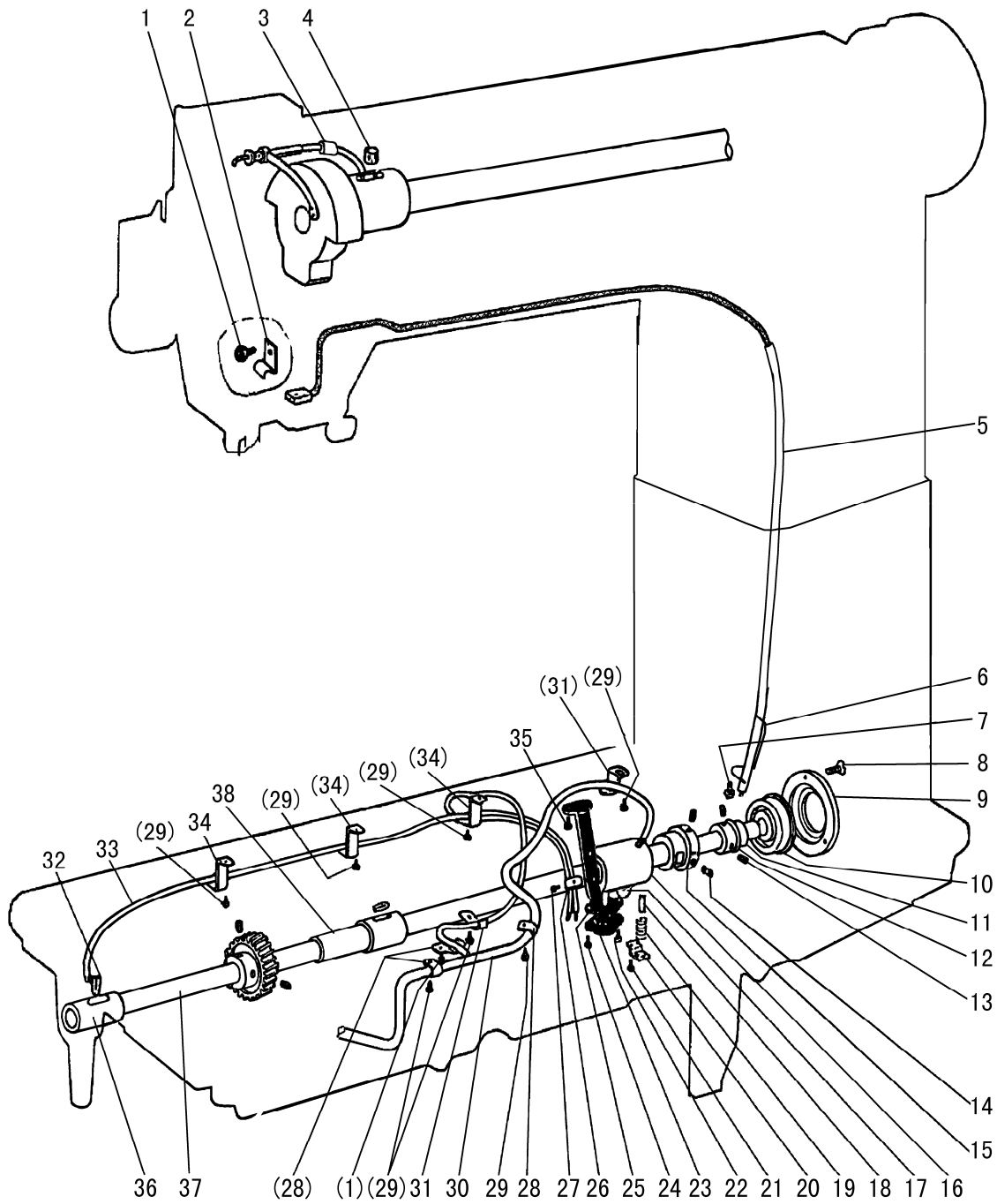

G.LOWER SHAFT & OIL LUBRICATION MECHANISM

Fig. No.	Part No.	Description	Pcs.	Remarks
G01	HA300C2030	Screw	4	SM11/64 (40) × 8
G02	H3200K0050	Holder	1	
G03	H32422C208	Pipe	1	
G04	H32175B304	Felt	2	
G05	H0206K7101	pipe & felt complete	1	
G06	H3200K0200	Holder	1	
G07	HA300B2170	Screw	3	SM11/64 (40) × 9
G08	HA7311C306	Screw	3	SM9/64 (40) × 7
G09	H3200H2060	Bearing holder	1	
G10	H3208H0661	Ball bearing	1	6004ZZNR/5K
G11	H3208H0662	Bushing	1	
G12	HA112D3012	Ring	1	
G13	HA105D0662	Screw	2	
G14	H3230K0751	Screw	2	SM11/64 (40) × 10
G15	H3230K0752	Bushing	1	
G16	HH404H7101	Lower shaft bushing middle (complete)	1	
G17	HA110E0672	Pipe	2	
G18	H1100I2070	Pin	1	
G19	H1100I2080	Spring	1	
G20	H1100I2110	Spring holder	1	
G21	H3204D6510	Screw	1	SM1/8 (44) × 4. 8
G22	H3215K0693	Screw	1	9/64 (40) × 5
G23	H3215K0692	Filter	1	
G24	H3215K0694	Screw	1	9/64 (40) × 7
G25	H32511K215	Base plate complete	1	
G26	H3215K0695	Holder	1	
G27	HA106B0676	Screw	1	
G28	H32311D606	Screw	3	
G29	HA300B2130	Pipe	6	SM11/64 (40) × 5. 5
G30	H4805J8001	Holder	1	
G31	H3200K0170	Holder	1	
G32	H32132B204	Oil wick	4	
G33	H3216K0070	Oil pipe & wick complete	1	
G34	H3200K0160	Holder	3	
G35	HA100E2150	Screw	2	SM11/64 (40) × 10
G36	H6314B7101	Lower shaft bushing left (complete)	1	
G37	H3200H2010	Lower shaft	1	
G38	H6316B7101	Lower shaft bushing right (complete)	1	

H.ACCESSORIES

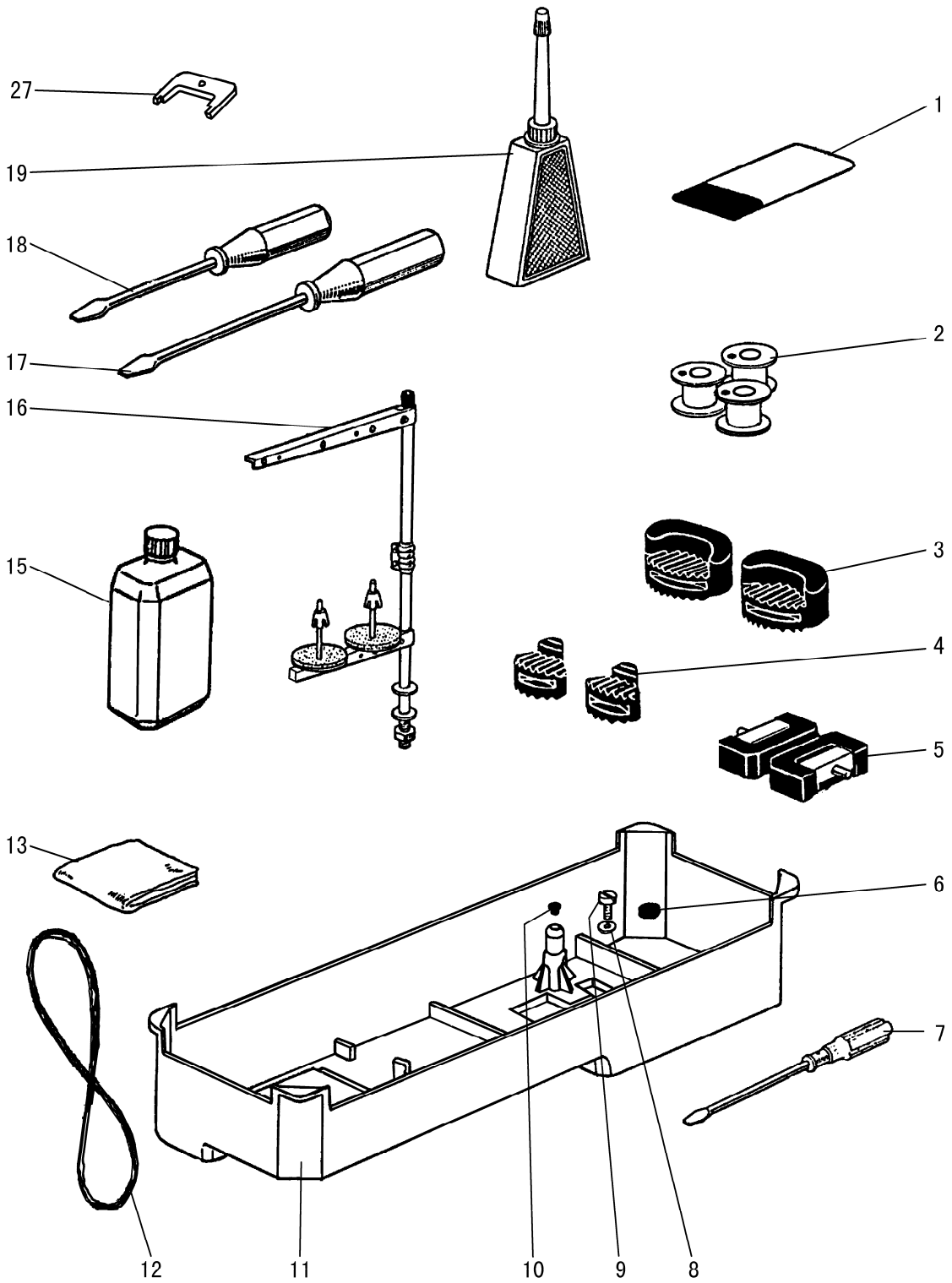

H.ACCESSORIES

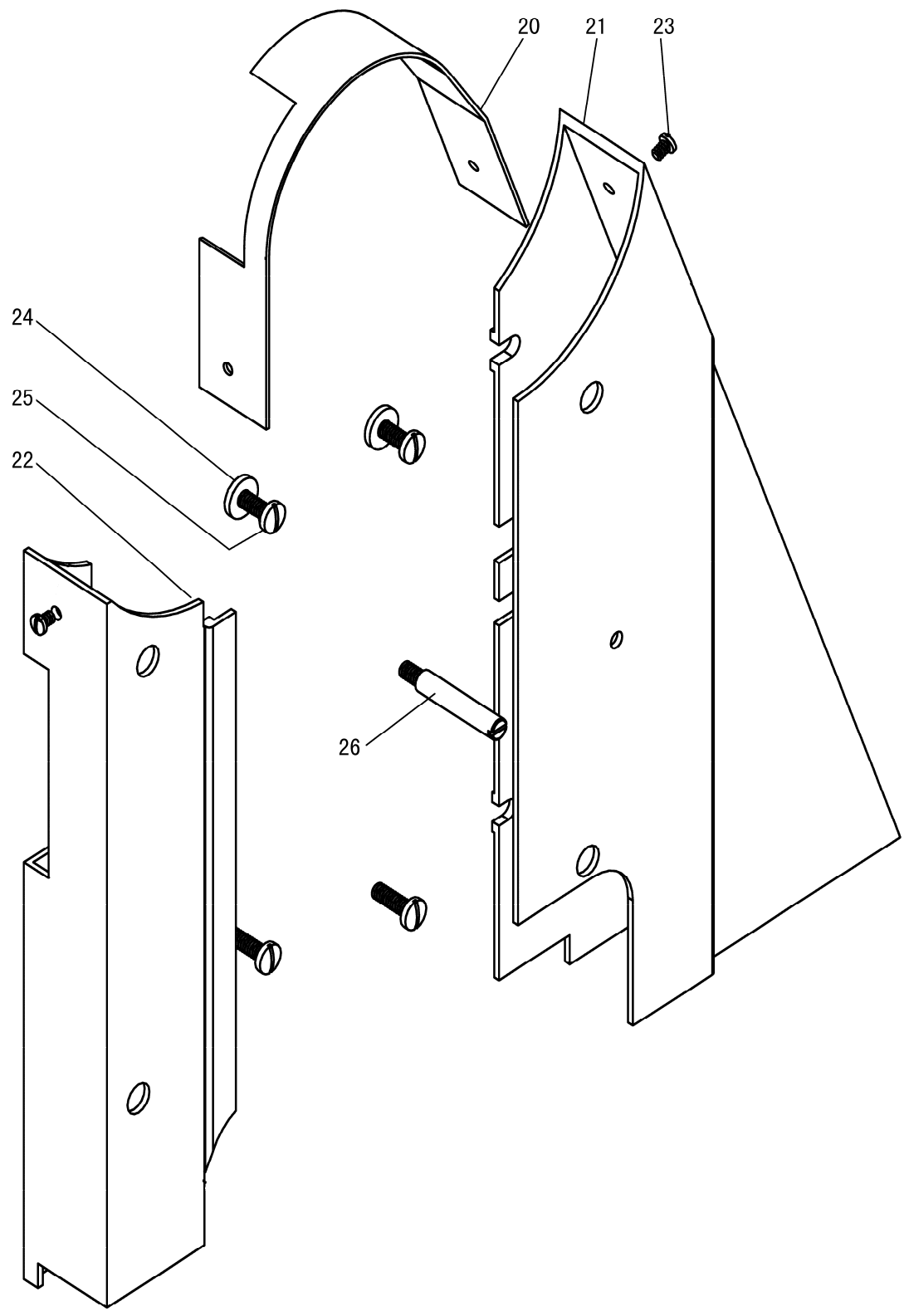

H.ACCESSORIES

Fig. No.	Part No.	Description	Pcs.	Remarks
H01	JZMt1900G1601	Needle	1	MT×190 16#
H02	HF971B8001	Bobbin	3	
H03	H4705K8001	Vibration preventing rubber	2	
H04	H4706K8001	Vibration preventing rubber	2	
H05	HA307J0067	Hinge complete	2	
H06	HA100J2120	Magnet block for reservoir	1	
H07	HA300J2070	Screw driver(large)	1	
H08	HA104J0653	Washer	1	
H09	HA104J0652	Screw	1	SM5/16 (28) × 12
H10	HA300B2090	Rubber plug	1	φ 8. 8
H11	H3213L0661	Oil reservoir	1	
H12	550	V-belt	1	
H13	HA100J2180	Vinyl cover	1	
H15	HA120J8001	Oil can	1	
H16	HA200J2030	Cotton stand	1	
H17	HA300J2200	Screw driver(middle)	1	
H18	HA300J2210	Screw driver(small)	1	
H19	HA100J2110	Oiler	1	
H20	HK504H8001	Belt cover (upper)	1	
H21	H6309L8001	Belt cover (right)	1	
H22	H6310L8001	Belt cover (left)	1	
H23	H200000360	Screw	2	SM11/64 (40) × 6. 2
H24	H6722N8001	Washer	2	
H25	H0207L8001	Screw	4	SM15/64 (28) × 18
H26	H0208L8001	Screw	1	SM15/64 (28) × 10
H27	HA704S0654	Adjusting plate for speed command disk	1	

SHANGHAI HUIGONG NO.3 SEWING MACHINE FACTORY

ADD: 1418, Yishan Road, Shanghai, China

Zip Code: 201103

Overseas Business: TEL: 86-21-64853303 FAX: 86-21-64854304

E-mail: highlead@online.sh.cn <http://www.highlead.com.cn>

The description covered in this manual is subject to change for improvement of the commodity without notice

2010.1. Printed