



HIGHLEAD

HLK-3020

**Direct Drive Electronic Bartacking Machine For Soft
Cushion**

**Instruction Manual
Parts Catalog**

SHANGHAI BIAOZHUN HAILING SEWING MACHINERY CO., LTD.

FOR YOUR SAFETY!



If you operate the sewing machine first time, please make sure to read the following instructions for your safety and proper operation.

In this technical manual, the notice **CAUTION** is mentioned at some paragraph to attract your attention for the safety. Please keep it in mind whenever you work with the sewing machine.

CAUTION is used as the notice to warn a possible danger to cause a wound

This technical manual explains the instructions how to operate and maintain the sewing machine. All information in this technical Manual are subject to change without notice. **ShangHai HuiGong CORPROTATION** has all the copyrights on this technical manual. Reprinting the parts or all of this technical manual is not allowed without permission.

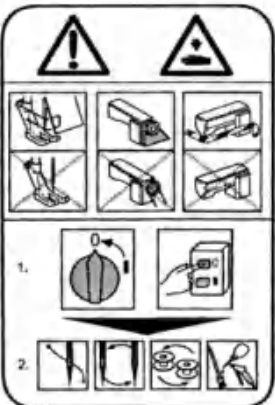
Explanations for the warning signs

NO	Warning sign	Meanings of warning sign
1		<p>Caution for sewing machine operation:</p> <p>Warning to operate the sewing machine without safety guards and to prohibit doing any operation except sewing while the power is turned on.</p> <p><Interpretation of sign></p> <ul style="list-style-type: none"> ·Do not operate without finger guard, eye guard, belt cover and other safety devices. ·Before threading, changing needle and
2		<p>Caution for a wound on the fingers:</p> <p>Warning to a possible danger to cause a wound on the fingers under the specified operation.</p>
3		<p>Caution for the fingers:</p> <p>Warning to a possible danger to be caught the fingers in the machine under the specified operation.</p>

Caution

- ★ For avoiding the sewing machine from the troubles, please do not operate the sewing machine under the following conditions.

1. Temperature and humidity

➤ **During operating:**

The atmosphere temperature should not exceeded more 350°C(95°F) or less 5°C(41°F).

During transportation:

The atmosphere temperature should not exceeded more 55°C(131°F) or less -10°C(18°F).

- **The relative humidity in the atmosphere should not exceeded more 85% or less 45%.**

2. Atmosphere for the machine operation

- **In the atmosphere filled with dust or corrosive gas.**
- **In the atmosphere filled with flammable or explosive gas.**

3. Power source voltage

- **In the place where the power fluctuation exceeds more or less 10% of the fixed power voltage.**
- **In the place where the power source cannot supply enough voltage to keep the motor running.**

4. Power source voltage

- **In the place where the power fluctuation exceeds more or less 10% of the fixed power voltage.**
- **In the place where the power source cannot supply enough voltage to keep the motor running.**

5. Noise

- **In the place near a high frequency transmitter or a high frequency welder.**
- **In the place filled with strong electromagnetic radiation or magnetic field.**

----- CONTENTS -----

1. STRUCTURE OF THE SEWING MACHINE	1
2. SPECIFICATION.....	2
3. INSTALLATION	2
3-1. Installation of the control box	2
3-2. Installation of the power switch	3
3-3. Installation of the oil pan	3
3-4. Installation of the sewing machine head.....	3
3-5. Installation of the spindle motor.....	4
3-6. Connection of the operation panel.....	4
3-7. Connection of the electric cables.....	5
3-8. Installation of the thread stand	5
4. LUBRICATION	7
4-1. Filling the oil tank.....	7
4-2. Oiling.....	7
5. PROPER OPERATION	8
5-1. Installation of the needle.....	8
5-2. Threading the upper thread	8
5-3. Winding the bobbin thread.....	9
5-4. Settling the bobbin.....	9
5-5. Setting the bobbin case	10
6. PROPER SEWING.....	10
6-1. Operation of the halt switch	10
6-2. The sewing operation.....	10
6-3. Adjustment of the thread tension.....	11
7. STANDARD ADJUSTMENT.....	12
7-1. Adjustment of the needle bar position.....	12
7-2. Adjustment of the position between the needle and the shuttle hook.....	13
7-3. Adjustment of the clearance between the shuttle hook and the needle.....	13
7-4. Adjustment of the clearance between the driver and the needle	13
7-5. Adjustment of the thread guide	14
7-6. Adjustment of the wiper.....	15
7-7. Adjustment of the presser foot	16
7-7-1. Adjustment of the presser foot position.....	16
7-7-2. Adjustment of the presser foot lift during the sewing.....	17
7-7-3. Adjustment of the presser foot timing.....	18

7-7-4	Adjustment of the presser foot standard height	19
7-8.	Adjustment of the bobbin winder	20
7-9.	Adjustment of the work holder	20
7-10.	Adjustment of the trimmer cam follower	21
7-11.	Adjustment of the position for the movable knife point	21
7-12.	Adjustment of the fixed knife position	21
7-13.	Adjustment of the thread take up spring swing stroke	22
7-14.	Adjustment of the thread take up spring tension	22
7-15.	Adjustment of the thread tail after the trimming	22
7-16.	Cancellation of the trimming function	23
7-17.	Adjustment of the upper thread tension release	23
7-18.	Adjustment of the mechanical home position	23
7-18-1.	Adjustment of the X timing belt tension	24
7-18-2.	Adjustment of Y stepping motor position	24
8.	MAINTENANCE	25
8-1.	Cleaning	25
9.	BAD SEWING CONDITION & ITS CAUSE AND REM EDY	26

零件样本

A.	ARM BED & IT'S ACCESSORIES (一)	29
B.	ARM BED & IT'S ACCESSORIES (二)	32
C.	SEWING MECHANISM (一)	36
D.	SEWING MECHANISM (二)	39
E.	X-Y TABLE MECHANISM (一)	42
F.	X-Y TABLE MECHANISM (二)	44
G.	X-Y TABLE MECHANISM (三)	47
H.	WORK HOLDER MECHANISM	49
I.	PRESSER FOOT MECHANISM (一)	52
J.	PRESSER FOOT MECHANISM (二)	54
K.	THREAD TRIMMING MECHANISM	57
L.	WIPER MECHANISM	60
M.	OIL LUBRICATION MECHANISM	63
N.	CABLE COMPONENT & DETECTOR MECHANISM	65
O.	ACCESSORIES (一)	67
P.	ACCESSORIES (二)	69

1、 STRUCTURE OF THE SEWING MACHINE

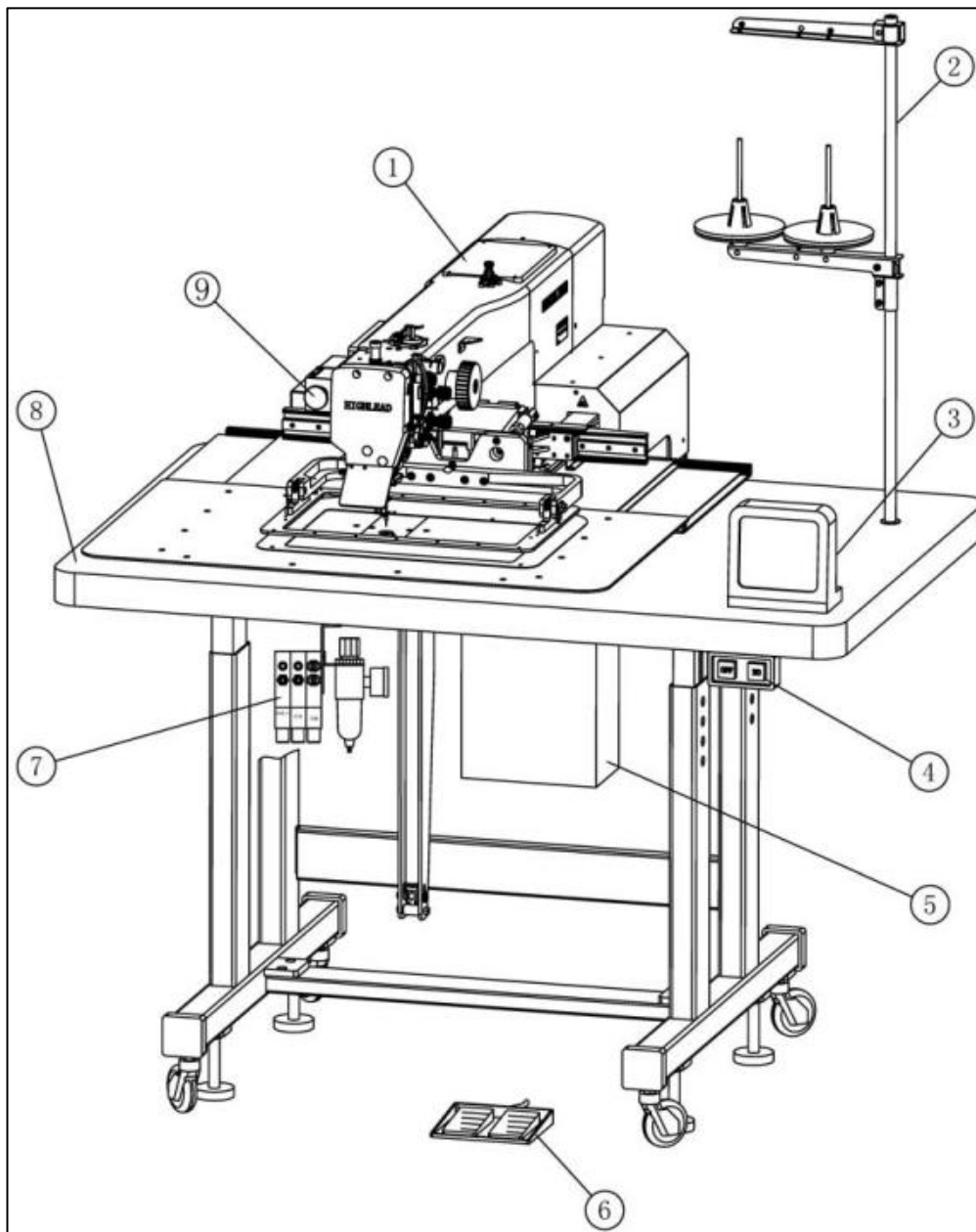

HLK-3020 electronic pattern sewing machine is constructed with the following main parts
①Sewing machine head ②Thread stand ③Operation Panel ④Power supply changer
⑤Control Unit ⑥Work holder foot switch ⑦Electromagnetic valve ⑧Wooden Table
⑨Halt switch

2 SPECIFICATION

Sewing area:	X-Direction(left / right) 150mm Y-Direction(forward / backward) 100mm
Maximum sewing speed:	2700 rpm
Sewing speed:	10 steps variable from 200 to 2700 rpm
Stitch length:	0.1 to 12.7mm
Stitch type:	Single needle lock stitch
Needle bar stroke :	41.2 mm
Thread take up lever stroke:	68mm
Class of needle:	DP × 17#18 (the standard specification)
Presser foot lift:	20 mm
Presser foot alternation:	Variable from 4mm to 10mm(4mm is standard)
Work holder lift:	25 mm
Hook:	Large size shuttle hook
Bobbin case:	With non racing spring
Bobbin:	Large size aluminum bobbin
Thread trimmer system:	Horizontal engagement with fixed knife and movable knife
Lubrication system:	Manual oiling and replenishment with the oil braids from the oil tanks
Lubrication oil:	White machining oil
X—Y drive system:	Stepping motor and X-Direction timing belt drive Y-Direction gear bar guide rail Intermittent or continuous feeding
Machine dimension:	1,200mm (W) × 1200mm (L) × 1,300mm (H)
main motor:	750W

3 INSTALLATION

Caution

- ★ The machine should be installed by the specialists who have enough experience for the sewing machine installations.
- ★ All the necessary electric wiring should be done by electric engineers who are qualified for the electric wiring.
- ★ If any damage or fault is found on the machine at the installation, please do not operate until it is repaired.
- ★ Please do not operate the sewing machine with excessive modifications from the standard specification.

3-1 Installation of the control box

If the control box is purchased without assembling to the table, the control box has to be installed underneath the table. Please install the control box with the instruction in the paragraph

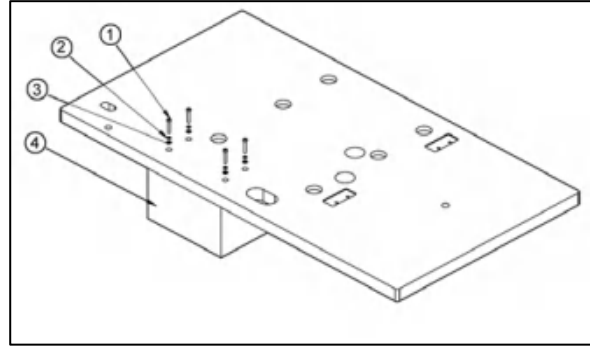

3-2 Installation of the power switch

If the power switch is purchased without assembling to the table, the power switch has to be attached with the following procedure.

- (1) Mount the power switch ① with the wood screw ② underneath the table as shown on the figure.
- (2) Fix the electric cords with the staples ③ underneath the table.
- (3) Hook up the connector ⑧ of the power switch ① to the control box ⑦.
- (4) Attach the power plug ⑤ to another end of the power switch cord ④. Connection of the foot switch
Connect the foot switch ⑥ to the control box ⑦. The foot switch is enclosed in the accessory box.

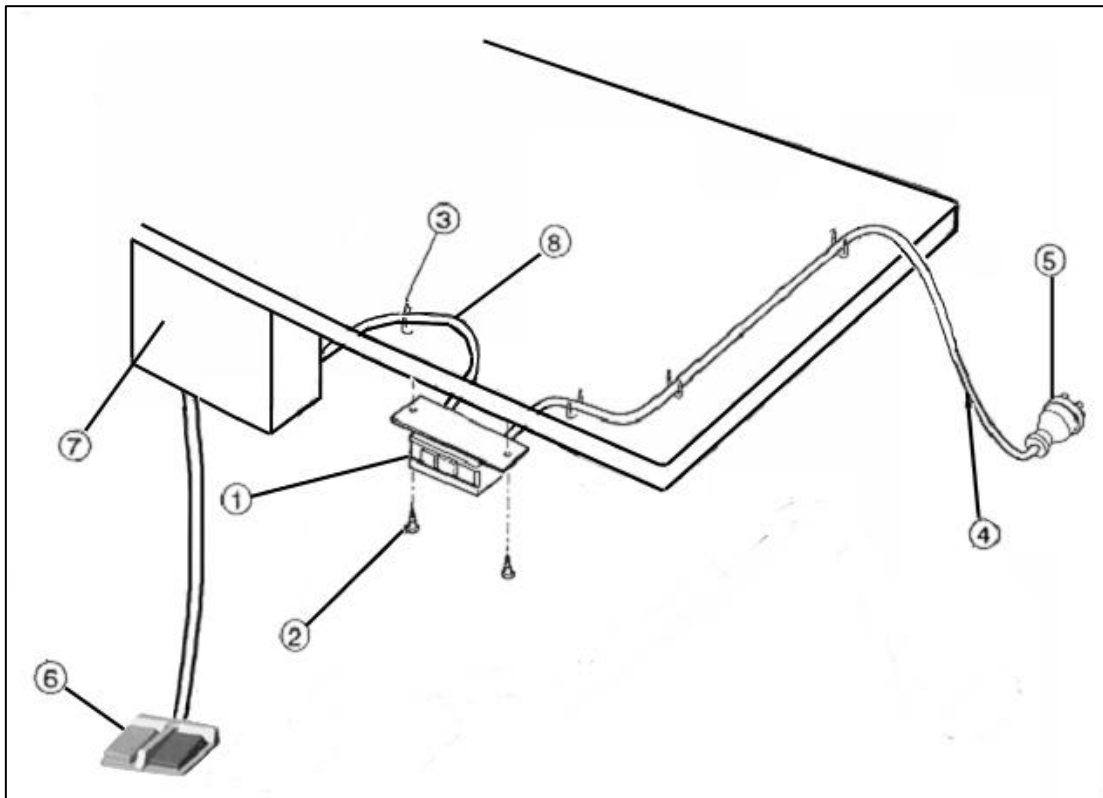

3-3 Installation of the oil pan

Fix the oil pan ① at its four corners on the table top with four.

3-4 Installation of the sewing machine head

★ For safety, please use a crane or a crane to install the sewing machine. At the same time to pay attention to table can not move, arm and bed have a stable support.

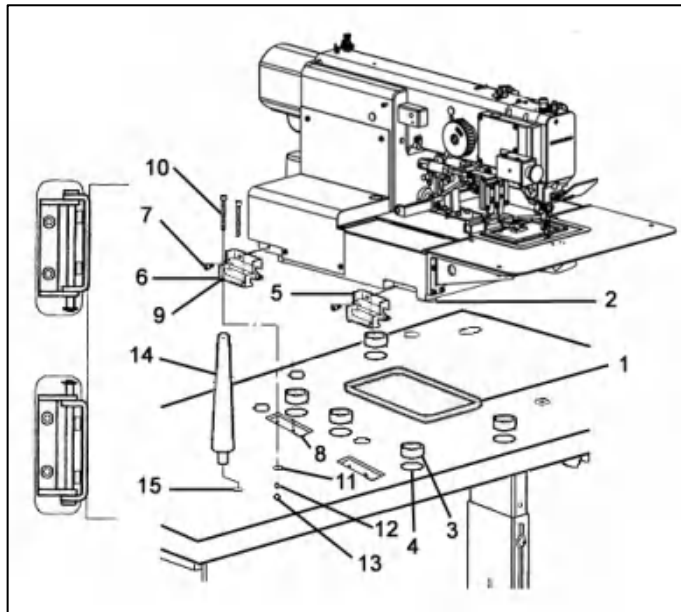

- (1)、Step on the rack at the foot of the brake, fixed frame, let bedplate can not move, take out of the right holder ⑦, and left bracket ⑧, fixed to the platen.
- (2)、Lift the sewing machine ②, remove the rubber pad attachment box ⑥ attached to the bottom surface of the seat lug.
- (3)、Remove the hinge shaft ③ into the seat inside the shaft hole, and then remove the rubber sleeve ④ and a hinge seat ⑤ is inserted into the hinge shaft ③ screws into the bedplate.
- (4)、Lift the sewing machine, the head to rotate about a hinge axis tilt, remove nitrogen spring ⑪ into the bottom of the machine base surface position, insert pin (up) ⑫, and then remove the support frame ⑰, spring ⑯, into the bottom of the machine base surface position, insert rod shaft ⑮, remove the rubber pad ⑱, fixed to the base.
- (5)、Remove the thick washer ⑬ with a screw fixing bracket ⑦, ⑧ of the width. Adjust the height of the nose, so that the gas spring ⑪ below the hole with the bracket ⑦, ⑧. At the long groove below, is inserted in the pin shaft (under ⑫), both sides into rings.
- (6)、Remove the support bar seat ⑨, fixed to the platen, reduce head height, will support frame ⑰ pressed into the slot of the support bar seat ⑨ insert rod shaft ⑩.
- (7)、Support ⑰, third gear can adjust the height of the sewing machine.

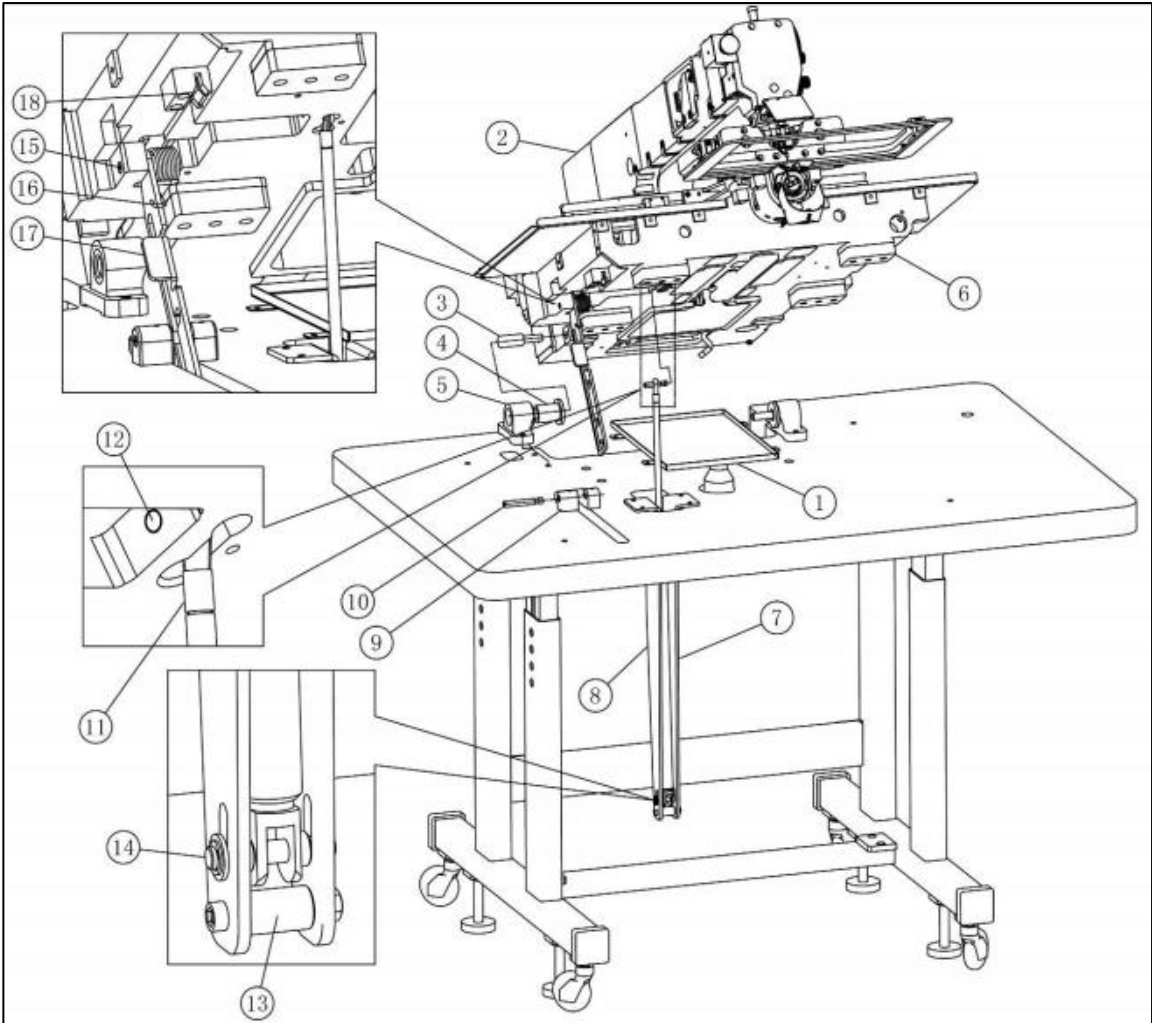

3-5 Installation of the spindle motor

If the spindle motor has been removed from the machine for the adjustment or the like, fix the spindle motor as the procedure described right.

- (1) Spindle motor according to right: put the signal cord upward.
- (2) Adjust the plane of the motor shaft alignment of the left on the motor mounting holes, 45 ° Angle adjustment.

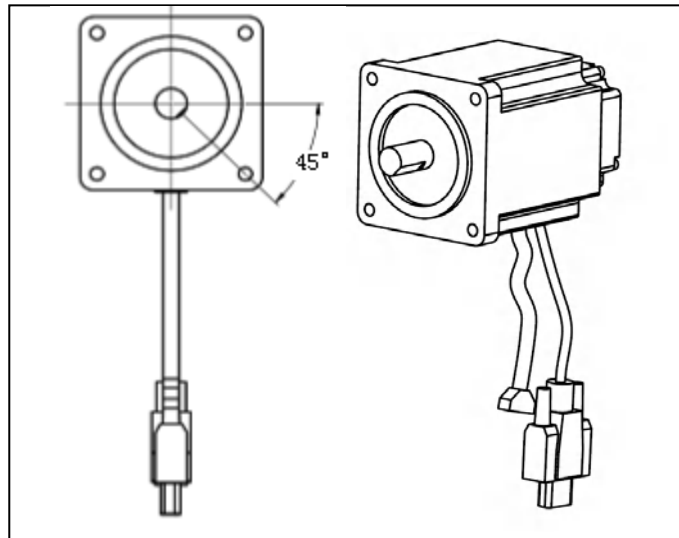

3-6 Connection of the operation panel

Please connect the operation panel with the instructions of operation panel manual enclosed in the packing.

3-7 Connection of the electric cables

Please make sure to ground the place where there is a  mark. Failure to do so may cause electric shock and/or malfunction.

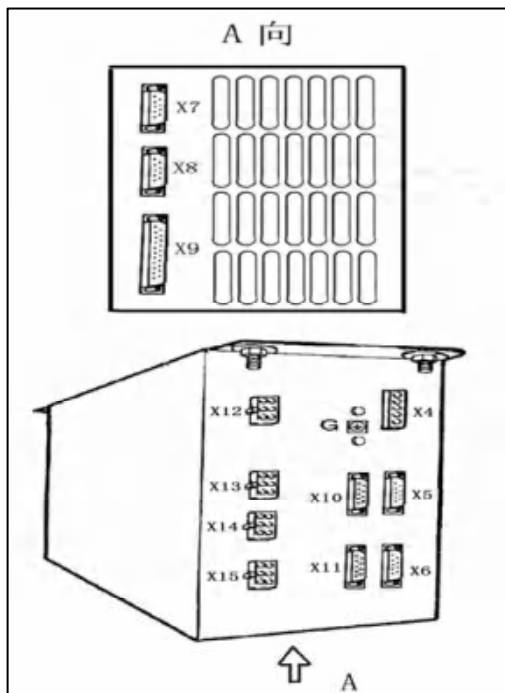
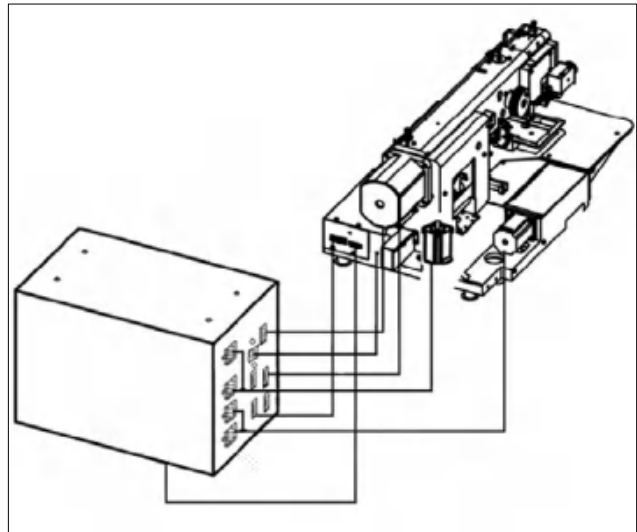

名称	连接
X4	Spindle motor power
X5	Spindle motor signal
X6	RS-232C (selection)
X7	Operation panel
X8	Foot switch
X9	Control signal one
X10	RS-232C (selection)
X11	Control signal two
X12	Y spindle stepping motor
X13	
X14	X spindle stepping motor
X15	
G	Grounding wires

3-8 Installation of the thread stand

- (1) Assemble the thread stand with the instructions enclosed in the packing.
- (2) Fit the thread stand ① in the thread stand hole on the tabletop.
- (3) Fix the thread stand ① firmly from the rear side of the table with tightening the nut ④ and the washers ②, ③.

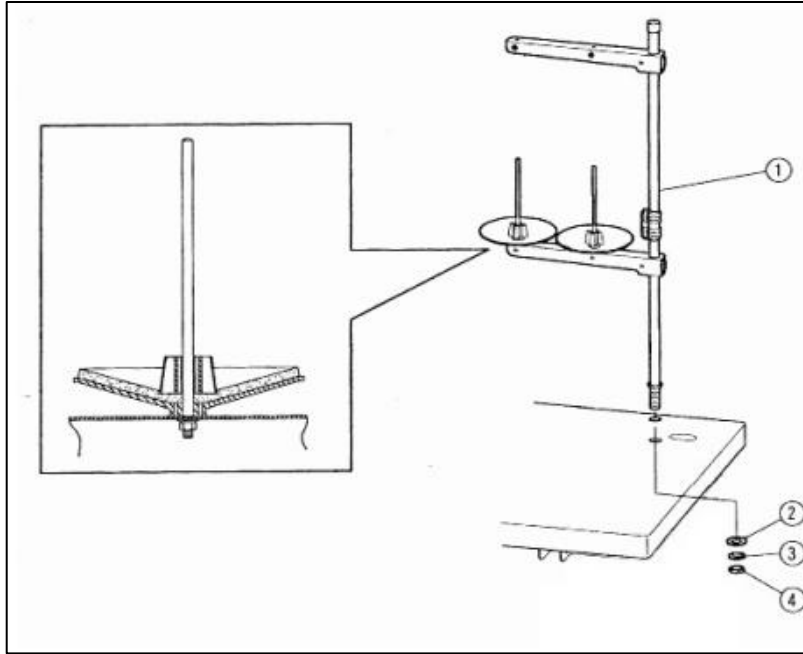

4 LUBRICATION

Caution

★Please make sure to turn power switch off before oiling.

★Please make sure to put some oil before starting the operation of the brand new machine or

NOTE : Please use high quality white machining oil.

4-1 Filling the oil tank

Pour the oil through the oil hole ① to the oil tank ② on the machine arm. Move the work holder by hand to the right end then, machine bed. Please Pour the oil through the oil hole ③⑤ to the oil tank, fill with the oil over level mark ④⑥ of the oil tank.

4-2 Oiling

Put some oil to red marked oil holes(NO. ⑦~⑧).

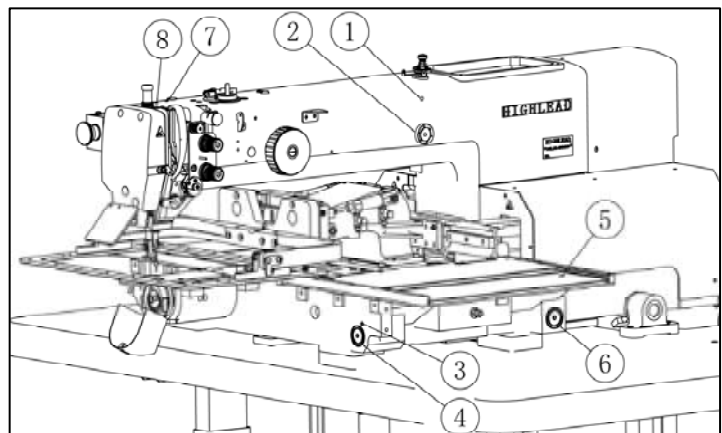

5 PROPER OPERATION

5-1 Installation of the needle

Caution

★ Please make sure to turn the power switch OFF before installing or replacing the needle.

★ Please pay attention for the fingers not to be wounded by the needlepoint.

- (1) Loosen the needle set screw ① then,
Insert the new needle ② until the
needle head is reached the end of the
hole of the needle bar ③ .
- (2) Fasten the setting screw ① with facing
the needle groove ④ to the front

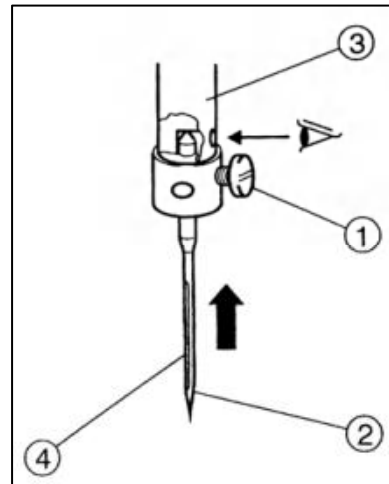

5-2 Threading the upper thread

Caution

★ Please make sure to turn the power switch off before threading the upper thread.

★ Please thread the upper thread with referring to the below figures.

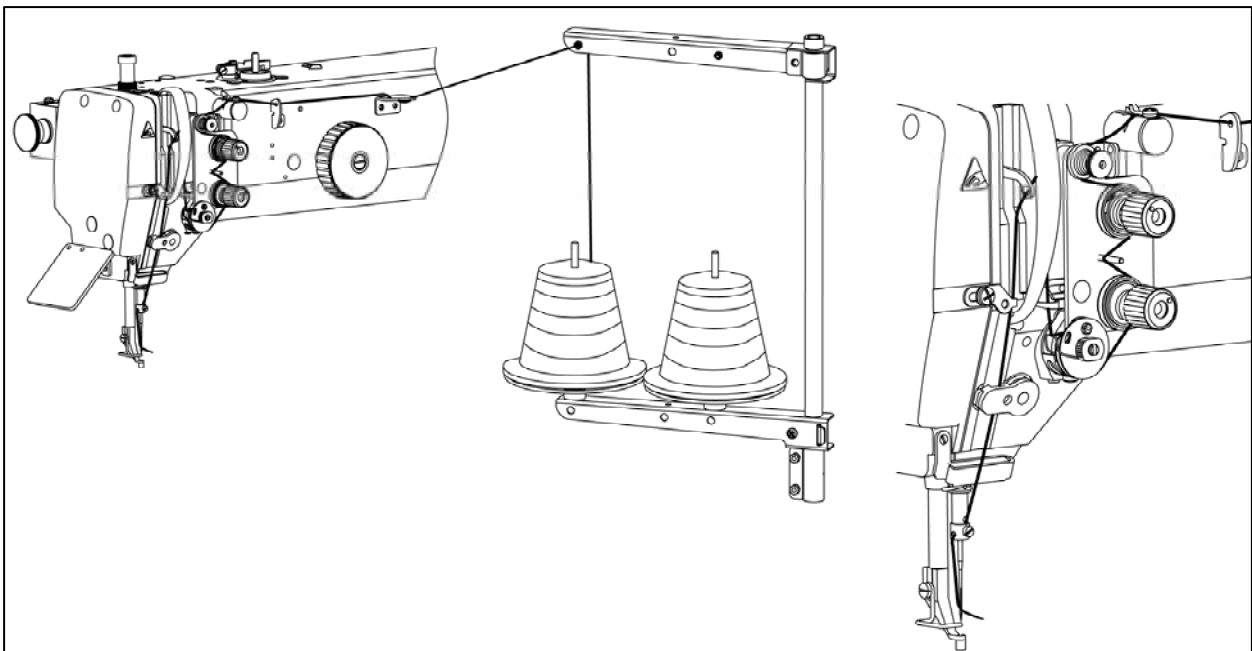

5-3 Winding the bobbin thread

★Please make sure to pull the upper thread out of the needle before winding the bobbin thread

- (1) Turn the power switch ON.
- (2) Pass through the thread from the thread stand①as shown on the right figure. then, wind the thread to the empty bobbin②in the arrow mark “a” direction couple times and insert the bobbin②into the bobbin winder③.
- (3) Push the adjust lever④in the arrow mark “b” direction.
- (4) Step on the gray color start foot switch⑤. The thread is kept winding to the Bobbin②while the gray color start switch is stepping on.
- (5) When the bobbin becomes full of the thread, the adjust lever③is returned to the original position.
- (6) Step the gray foot switch to exit winding mode. .
- (7) To wind the bobbin thread during the sewing operation, carry out above (2) to (7) procedure, then, the bobbin winding is performed automatically.

For the details ,please refer to the instructions on the technical manual [Operation Panel].

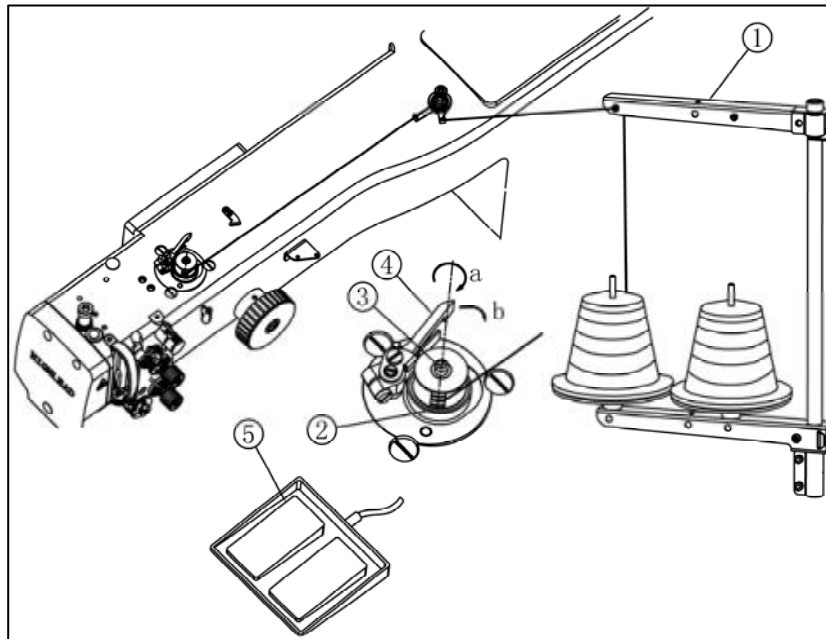

5-4 Settling the bobbin

- (1) Set the bobbin②into the bobbin case①.
- (2) Pull the bobbin thread③into the slit④and pass the thread through the thread hole⑤.
- (3) At this time, pull the bobbin thread③then, check with the bobbin②if it is rotated to the arrow direction. if it is not, set the bobbin②into the bobbin case①over again to get the proper rotation.

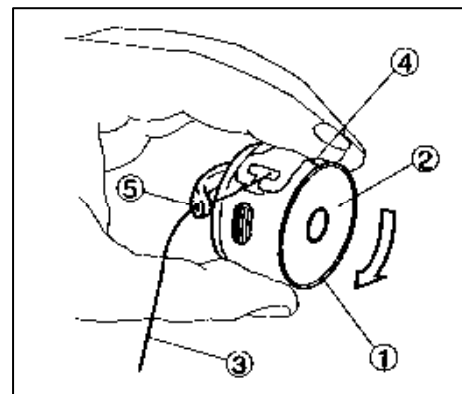

5-5 Setting the bobbin case

- (1) Set the needle bar to its highest position then, open the cylinder cover①.
- (2) Open the bobbin case latch lever②fully then, fit it securely in the inner hook③.

[NOTE]Please pull the bobbin thread about 2.5mm out of the thread hole(NO.4)of the bobbin case.

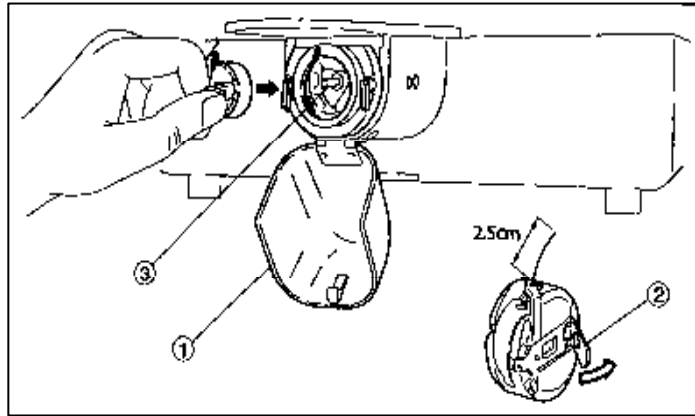

6 PROPER SEWING

6-1 Operation of the halt switch

If an incident such as a thread breakage, needle breakage and any other incidents are happened during the sewing operation, please hit immediately the halt switch. The sewing machine running is stopped instantly.
Caution

- ★ Before start the sewing operation, please make sure the location of the halt switch and keep it in mind the function and how to use it.
- ★ Please keep away the hands and the face from the needle during the sewing operation.

- (1) Press the HALT switch ①, All operations will stop, and the sewing machine will stop at the needle UP state without trimming the thread.
- (2) Remove the cause of the abnormality.
- (3) To continue sewing, turn the HALT switch to the right. The switch will be unlocked. (For the details ,please refer to the instructions on the technical manual [Operation Panel].)
- (4) When the start switch②(left)is pressed again, the operation will start .

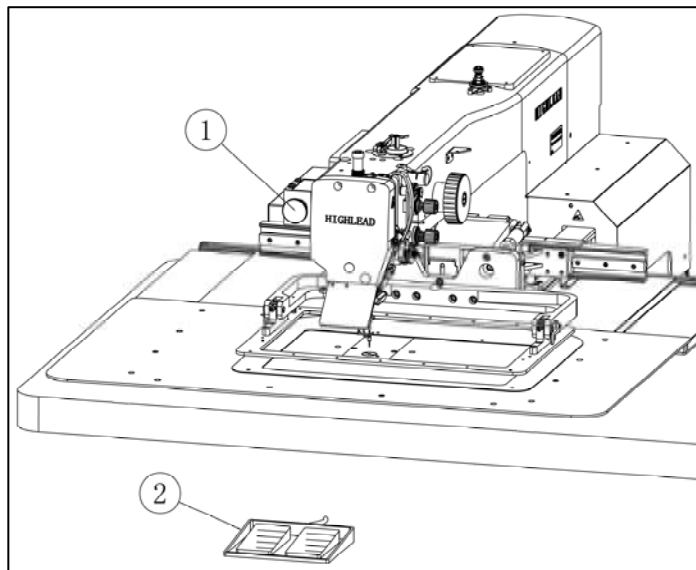

Caution

- ★ Depending on the shape of the work holder, the collision may be happened with the work holder and the presser foot while the work holder is on the way back to the home position. For avoidance of this accident, before starting the sewing operation . program the work holder returning home with the operation panel of the control box to trace the sewing pattern.

6-2 The sewing operation

Caution

- ★ It is very dangerous to operate the sewing machine without the safety guards(Eye guard: belt cover, Link cover, Finger guard etc.).

- ★ Please make sure to always operate the sewing machine with the safety guards.
- ★ Please do not put unnecessary articles except for the sewing operation on the tabletop.
- ★ Please keep the hands and the face away from the needle.

- (1) Turn the power switch ① ON.
The collision may be happened with the work holder and the presser foot depending on the work holder shape when the work holder is moved to original position.
- (2) When the start switch ② (left) is pressed, the work holder ③ will go down, the operation will start.

For the details, please refer to the instructions on the technical manual [Operation Panel].

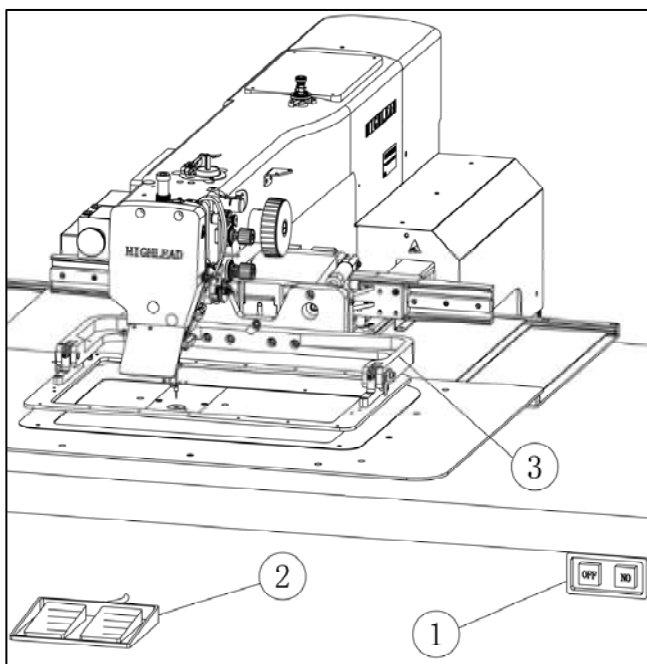

6-3 Adjustment of the thread tension

The thread tension between the upper and bosom thread should be balanced in the best condition.

When the upper thread tension is well balanced with the bobbin thread tension, both threads are interlocked along the centerline of fabric layers as shown on the below figures.

NOTE Normally weaker bobbin thread tension brings better sewing quality.

So it is prefer to set bobbin thread tension first and then set upper thread tension.

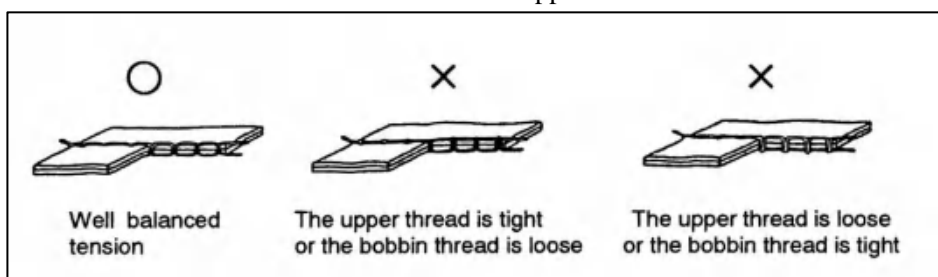

(1) Bobbin thread tension

Adjust the bobbin thread tension with the thread tension adjusting screw ② on the bobbin case ①. The thread tension becomes loose if turn the thread tension adjusting screw ② to the counter clockwise, and the thread tension becomes tight if turn it to the clockwise.

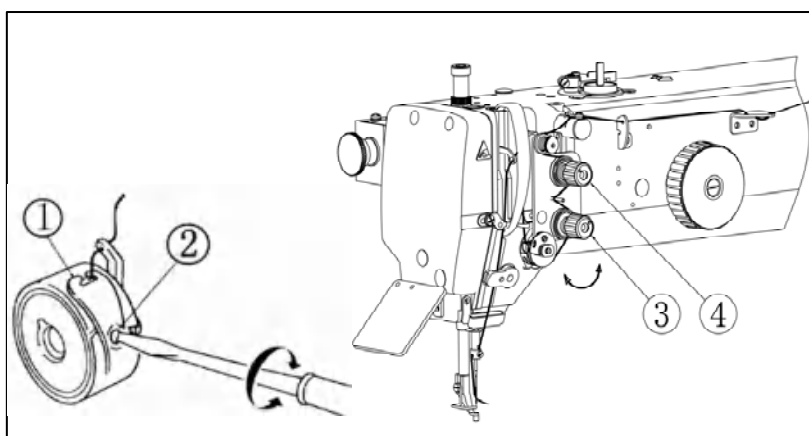

(2) Upper thread tension

Adjust the upper thread tension based on the bobbin thread tension. For this adjustment, turn the thread tension adjusting nut③④. The upper tread tension becomes tight if turn the thread tension adjusting nut③④ to the clockwise, and the upper thread tension becomes loose if turns it to the counter clock wise.

7 STANDARD ADJUSTMENT

Caution

- ★ Please make sure to turn the power switch OFF before adjust the sewing machine.
- ★ If the adjustment is required under the power switch is ON, keep the start foot switch away from the foot.
- ★ Be careful not to be wounded by the needle or the inner hook point.
- ★ Please make sure to put the safety guards(Eye guard, Belt guard, Link cover and finger guard etc.)back on the original location after the sewing machine adjustment.

7-1 Adjustment of the needle bar position

- (1) Turn the power switch OFF.
- (2) Turn the sewing machine pulley by hand then, stop the needle bar①at the lowest position.
- (3) Remove the rubber plug②from the face plate then, loosen the needle bar holder setscrew③.
- (4) Move the needle bar①to the position where the needle bar timing mark A is matched to the needle bar bushing bottom line④then, tighten the needle bar holder setscrew③.

NOTE: If the needle class is DP×5, match the needle bar timing mark B to the needle bar bushing bottom line④.

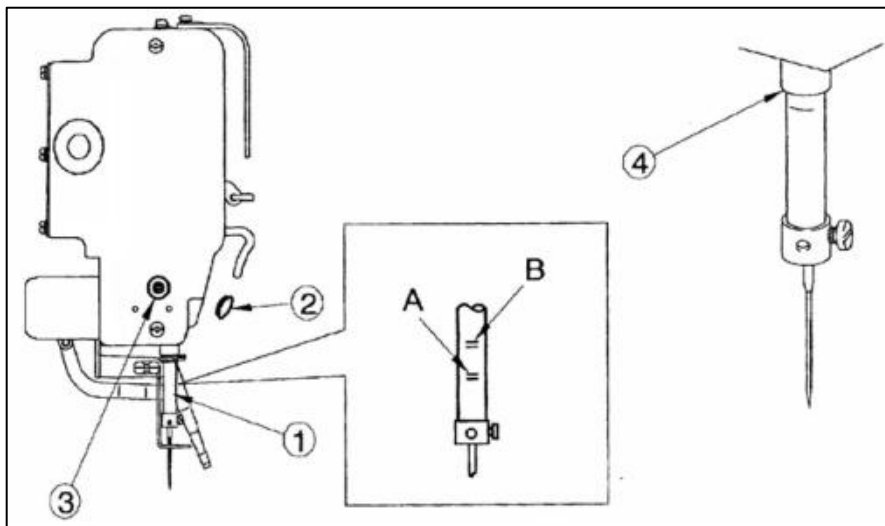

7-2 Adjustment of the position between the needle and the shuttle hook

- (1) Turn the power switch OFF.
- (2) Turn the sewing machine pulley by hand then, move up the needle bar① from the lowest position and stop it at the position② where the needle bar timing mark C is matched to the needle bar bushing bottom line.

NOTE: If the needle class is DP×5, match the needle bar timing mark D to the needle bar bushing bottom line②.

- (3) Open the cylinder cover②.
- (4) Remove the bobbin case③.
- (5) Turn the hook retainer lever⑤ then, remove the hook retainer⑥.
- (6) Loosen the driver setscrew⑨ then, move the driver(No.10) and adjust the shuttle hook point⑦ to be matched with the center line⑧ of the needle.

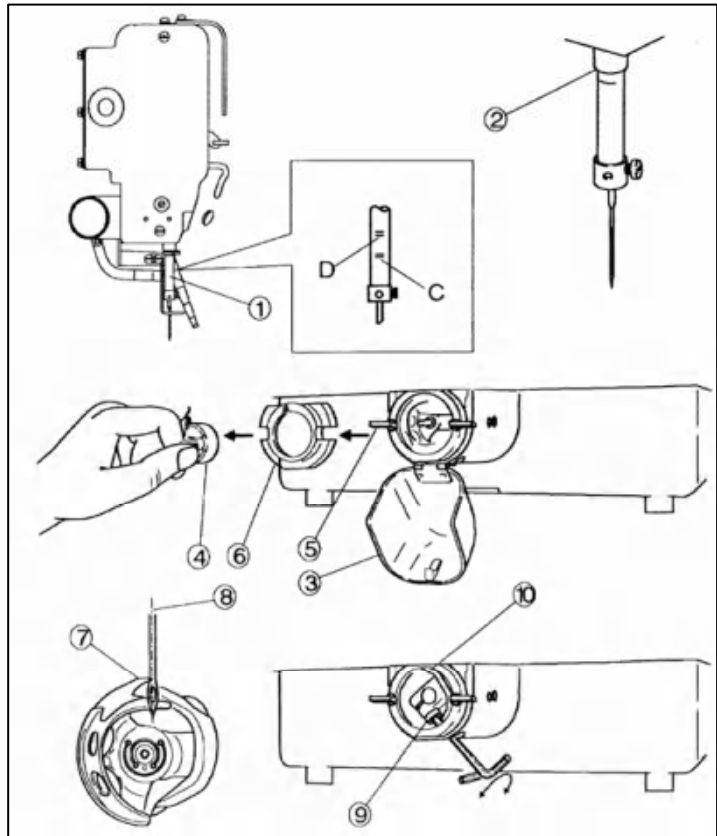

- (7) After the adjustment, tighten the driver setscrew⑨ and put the bobbin case④, the hook retainer⑥ and the hook retainer lever⑤ back to the original location then close the cylinder cover②.

7-3 Adjustment of the clearance between the shuttle hook and the needle

- (1) Please take the same procedures as above paragraph 7-2. from(1) to(5).
- (2) Loosen the outer hook setscrew③ and turn the eccentric pin④ so that the clearance between the shuttle hook point and the needle becomes 0.05~0.1 mm.
- (3) After the adjustment, securely tighten the outer hook setscrew③ and put the hook retainer and the bobbin case back to the original location then, close the cylinder cover⑤.

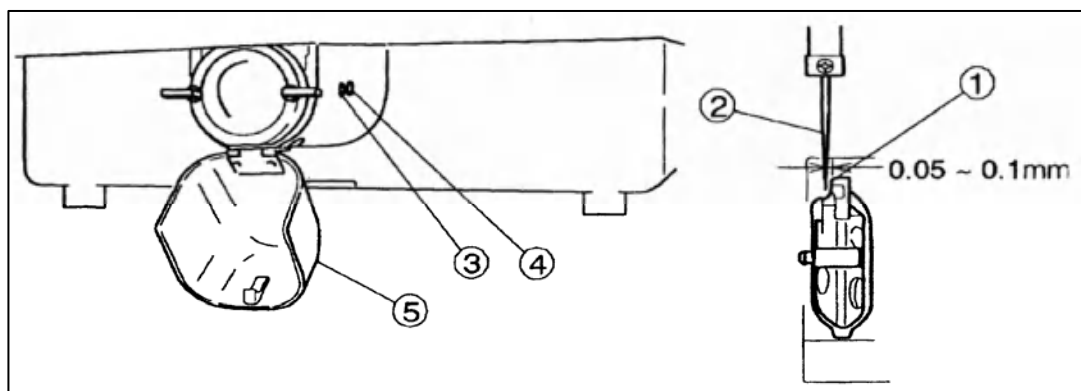

7-4 Adjustment of the clearance between the driver and the needle

- (1) Please take the same procedures as above paragraph 7-2. from(1)to(5).
- (2) Please make sure the clearance between the shuttle hook point and the needle has been adjusted 0.05~0.1 mm at above procedure 7-3 Adjustment of the clearance between the shuttle hook and the needle.

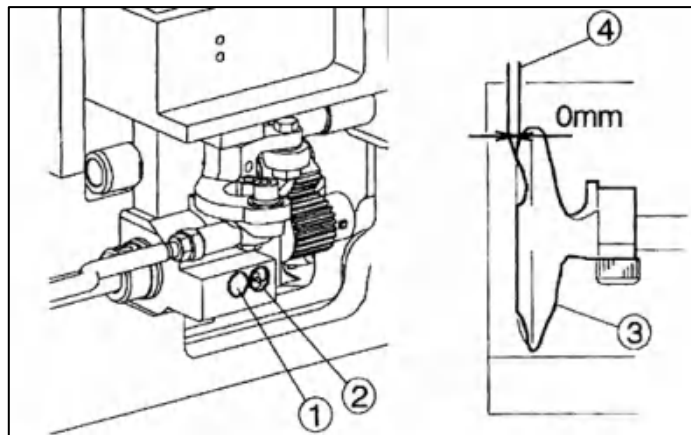

- (3) Loosen the driver setscrew①and turn the eccentric pin②so that the clearance between the driver③and the needle④can become 0.
- (4) After the adjustment, securely tighten the driver setscrew①and put the hook retainer and the bobbin case back to the original location then, close the cylinder cover⑤.

7-5 Adjustment of the thread guide

- (1) Remove the E-shaped snap ring③which is engaging the movable knife②and the link①then, loosen the setscrews④and remove the sliding plate(S) ⑤.
- (2) Loosen the setscrews⑩and move the thread guide⑥to the position where the needle center line⑧divides the needle groove⑦evenly and the rear side line⑨of the needle is aligned with the shoulder⑨ of the thread guide⑥. At this time, make sure that there is some clearance between the hook retainer and the thread guide⑥at least the upper thread can be passed smoothly through it(standard clearance is 0.8mm). If this clearance is too wide, it causes the trimming failure and if this clearance is too narrow, it causes the sewing condition disturbance, the trimmed upper thread tail uneven and the locking up the hook with the upper thread.

- (3) After the adjustment, engage the link ①of the trimmer mechanism with the movable knife②with the E shaped snap ring③and put the sliding plate(S) ⑤back on the original location then, tighten the setscrews④. At this time, set the sliding plate(S) ⑤so that the needle⑪can come down to the center ⑫of the needle hole of the needle plate.

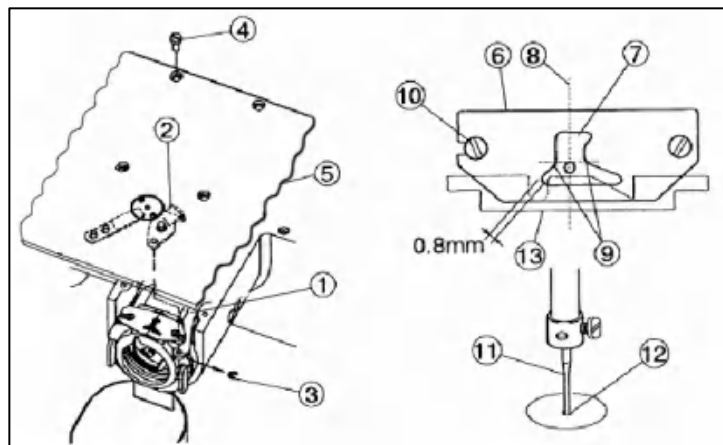

7-6 Adjustment of the wiper

- (1) Loosen the wiper setscrew③and adjust the wiper①to be positioned where the wiper①passes under the needle point②with about 2 mm clearances right after the sewing machine is stopped running at the needle upper position (the thread take up lever's highest position).

[NOTE] When the presser foot position or the presser foot lift is changed, the wiper①may collide with the presser foot④.in that case, please do not use the wiper①.If do not use the wiper ①,cancel the wiper function with operation

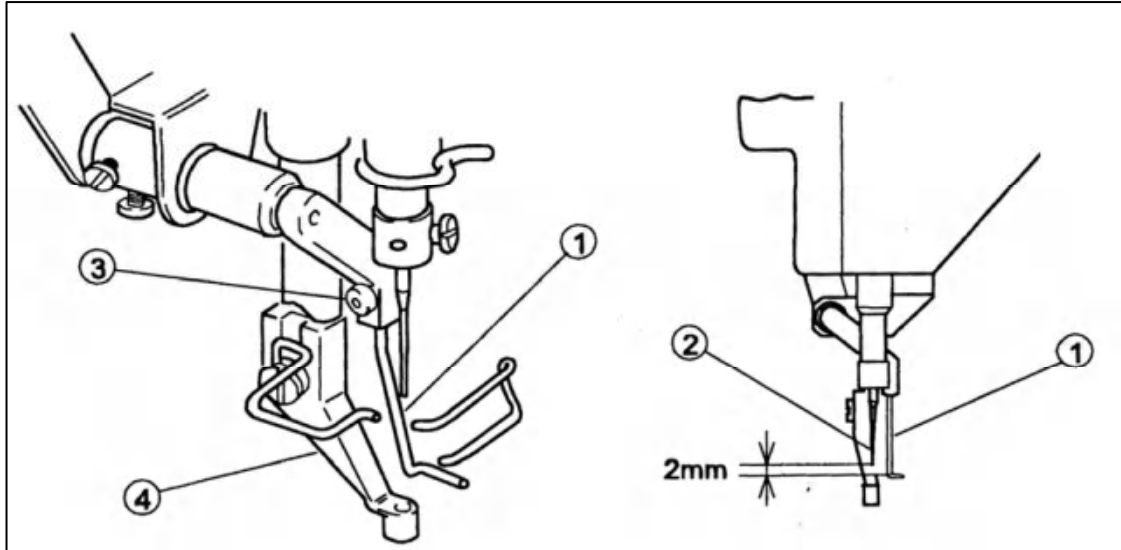

7-7 Adjustment of the presser foot

[NOTE]The presser foot is a very important part to form the fine stitches.

It moves simultaneously with the needle and stabilize the needle penetrating area of the sewing material with pressing down it, when the needle sticks into or pulls out the sewing material and prevent the skip stitch or the over penetration happening. Please adjust the presser foot properly to the sewing materials with the following instructions.

7-7.1 Adjustment of the presser foot position

[NOTE]Please always adjust the presser foot position when the thickness of the sewing material is changed.

- (1) Turn the power switch OFF.
- (2) Remove the face plate①and the link cover②.
- (3) Turn the sewing machine pulley by hand and stop the needle bar③at the lowest position. At this time, make sure the setscrew⑤of the eccentric cam④is positioned right beside the center line of the upper shaft. This is the standard position of the eccentric cam④. If the eccentric cam④is off from this position, set it back to the standard position with the instructions on the paragraph[7-6-3. Adjustment of the presser foot timing]in the following page.
- (4) Turn the sewing machine pulley by hand and stop the needle at the highest position(this is also the thread take up lever's highest position). At this time, loosen the setscrew⑨ of the upper feed lock crank shaft⑧and adjust the center line of the bell crank⑥to be parallel with the presser foot bar⑦.

- (5) Insert the sewing material⑩under the work holder⑪and turn the sewing machine pulley by hand then, stop the presser foot⑫at the lowest position.
- (6) Loosen the presser foot bar setscrew⑭and move the presser foot bar⑦then, adjust the presser foot⑫ position to be become the clearance between the bottom surface of the presser foot⑫and the surface of the sewing material 0~0.5mm. At the same time, rotate the presser foot bar⑦for the needle⑬to come down to the center of the needle hole of the presser foot⑫.
- (7) After the adjustment, put the face plate①and the link cover②back on the original location.

[NOTE]The lower position of the presser foot, the more effective for the skip stitches. However, if the presser foot becomes to Press the sewing material, the movement of the presser foot mechanism generates a slight noise. And also, the presser foot stays longer to hold the sewing material, so the upper thread tension becomes loose or the sewing pattern forming gets out of shape because the presser foot catches the surface of the sewing material. For avoiding these troubles, please lower the presser foot as small as possible.

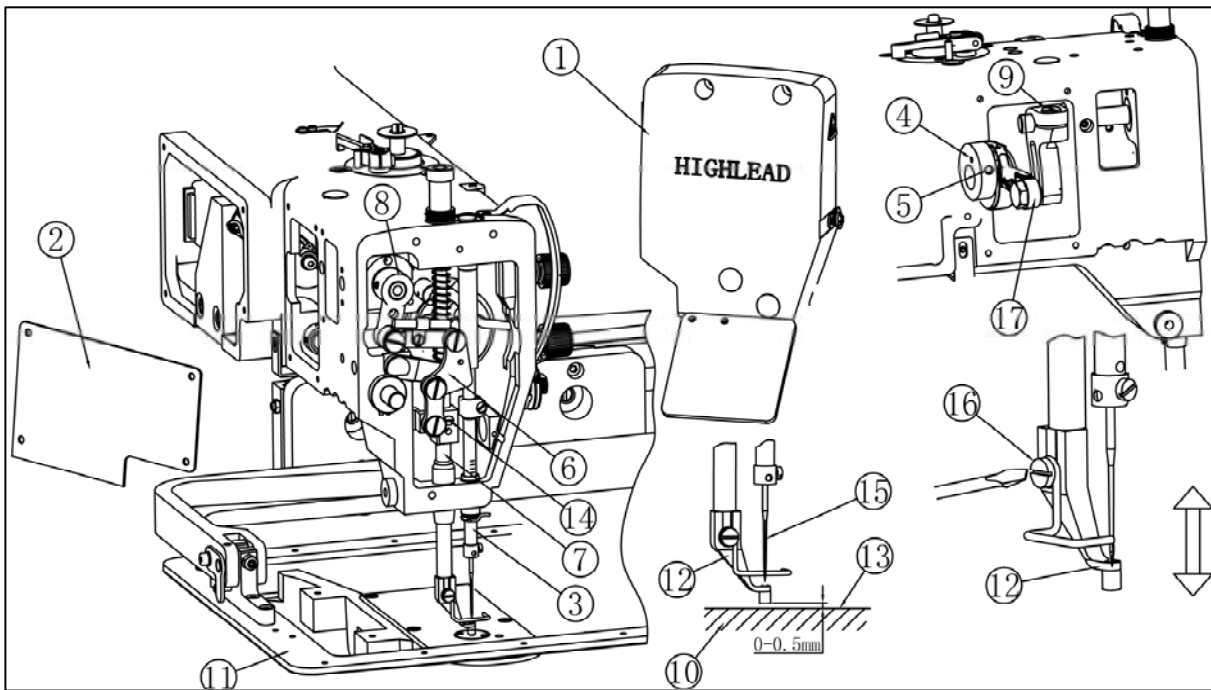

[NOTE]If the thickness of the sewing material changes very often, it is recommended to take the easy way for the adjustment of the presser foot position with the method that change only the fixed position of the presser foot after fixed the presser foot bar at higher position. For this adjustment, loosen the setscrew⑯then, move the presser foot ⑫up and down.

7-7.2 Adjustment of the presser foot lift during the sewing

[NOTE]The presser foot lift during the sewing can be adjusted 0 and 2~10mm.

- (1) The presser foot lift during the sewing becomes 4~10mm at the condition which the connection of the link②and the lever③with the shoulder screw①is as shown on the figure and it becomes 2 to 4 mm if the connection is made with A hole, and it becomes 0 mm if the connection is made with B hole.
- (2) The stepping lift is adjusted 4mm when the sewing machine is shipped from the factory.
- (3) For the adjustment at the each range of the presser foot lift, remove the link cover④then, loosen and move the adjust bolt⑤.
- (4) If the link②connection is changed to A or B hole, the presser foot position is also changed. So reset the presser foot position with adjusting the position of the presser foot bar or the presser foot itself with loosening their setscrews⑥or⑦.
- (5) Regarding the running noise and the vibration, the higher lift effects worse. So adjust the presser foot lift during the sewing as small as possible.
- (6) After the adjustment, put the link cover④and the face plate⑧back on the original location.

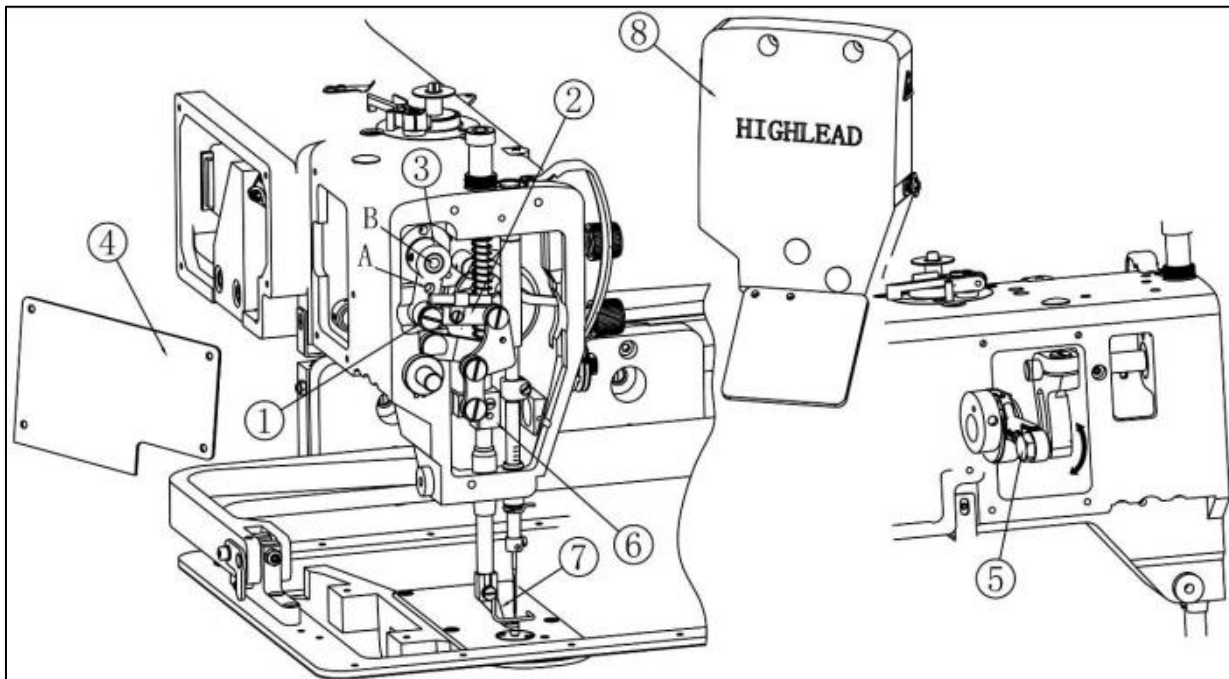

7-7.3 Adjustment of the presser foot timing

[NOTE] The presser foot up and down movement during the sewing synchronizes with the needle up and down movement. With changing this synchronized timing to the sewing materials, the skip stitches can be prevented or the seam tightness can be improved.

For example, the delay of the presser foot timing against the needle movement prevents the skip stitches especially to the thin materials, and the advance of the presser foot timing can improve the seam tightness especially to the thick materials.

- (1) Remove the link cover①.
- (2) Loosen the setscrew “C” of the eccentric cam②.
- (3) Turn the sewing machine pulley by hand and stop the needle bar③at the lowest position. At this stage, the setscrew “A” of the eccentric cam②is positioned right beside the center line of the upper shaft. This is the standard position for the eccentric cam②.
- (4) Loosen the setscrew “A” of the eccentric cam②.
- (5) Hold the eccentric cam②and turn the sewing machine pulley slowly by hand. If turn the sewing machine pulley to the arrow direction “D”, the presser foot timing against the needle movement is delayed, and if turn the pulley to the opposite direction, the timing of the presser foot is advanced.
- (6) After the adjustment, tighten the setscrew “A” and “C” in turn with slightly pushing the eccentric cam②to the arrow direction “E”.
- (7) Put the link cover①back on the original location.

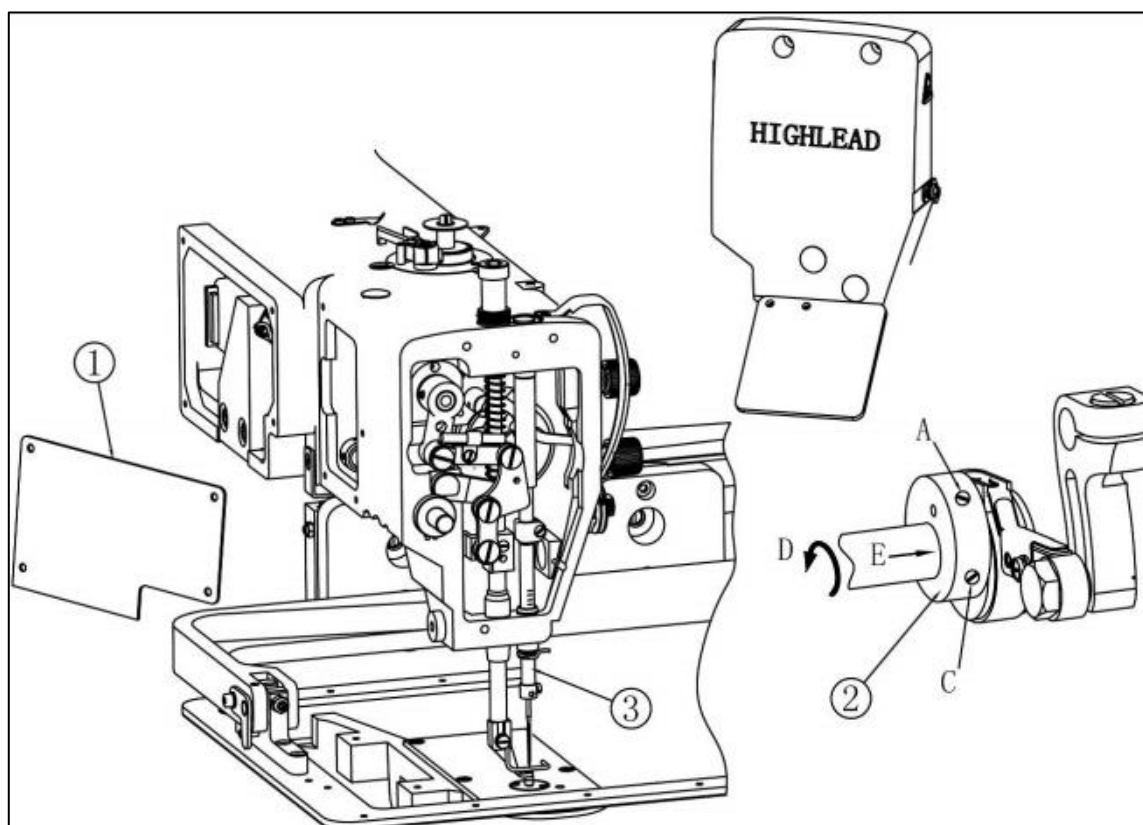

7-7.4 Adjustment of the presser foot standard height

Note: the standard height of the presser foot is 20 mm.

- (1)、Open the head panel , the attachment block ① into the needle on the surface, presser foot ② down to the gauge①, height of 20mm.
- (2)、Open the cover of the motor③, release the screw④, rotate the detection chip⑤ and make its cutting edge locate in the center of the origin of the detector ⑥ , then insert the A hole with a thin long axis, and lock the screw ④.
- (3)、If the middle pressure foot ② height 20mm error is big, can loosen the screw ⑦or loosen the screw ⑧ to carry on the adjustment all may.

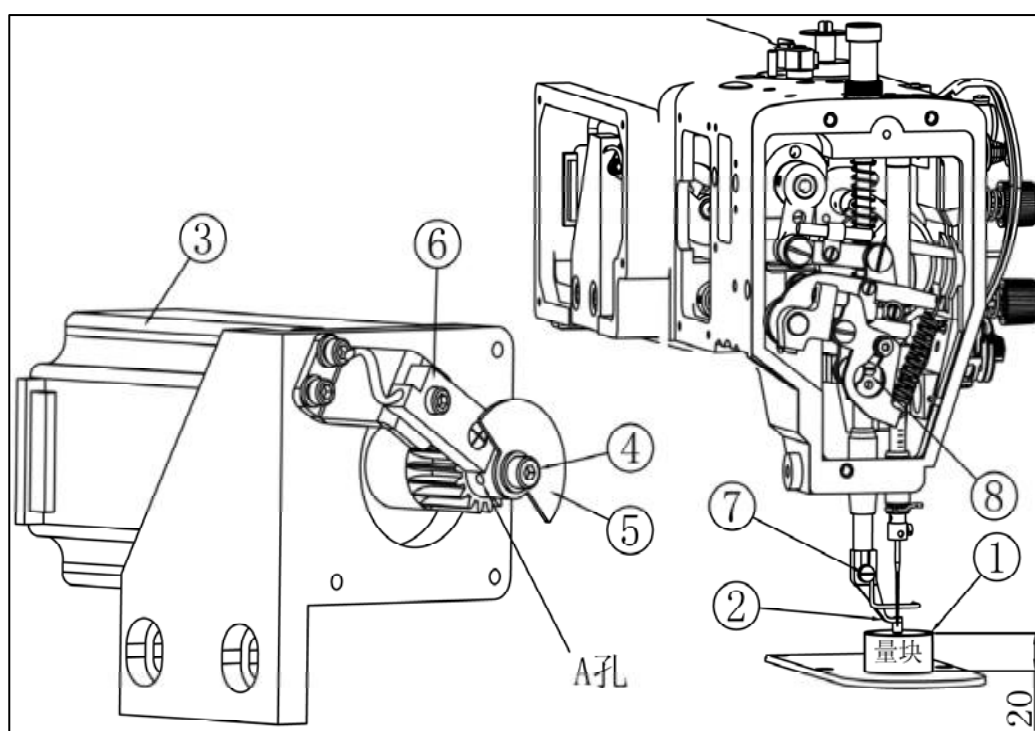

7-8 Adjustment of the bobbin winder

(7) Adjustment of the winding volume

Loosen the setscrew②of the adjusting lever①and adjust the position of the adjusting lever①. If move the adjusting lever①to the arrow direction “a” the Winding volume is reduced, and if move the adjusting lever①to the arrow direction “b”, the winding volume is increased. The winding volume is adjusted 80%of the full volume when the sewing machine is shipped from the factory.

(8) Adjustment of the proper position of

the bobbin winder Firstly . loosen the setscrews③ and④⑤ of the bobbin winder and put the empty bobbin on the rotating shaft⑥then , push the adjusting lever ① to the arrow direction “a”. Secondary. move the whole bobbin winder to the arrow direction “C” and stop it at the position where the empty bobbin is rotated then , This is the proper position of the bobbin winder.

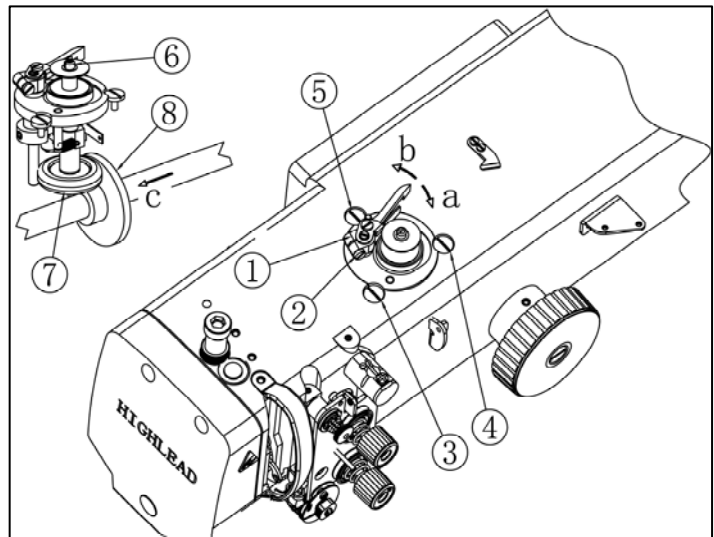

7-9 Adjustment of the work holder

If the sewing material is thick and the work holder does not press it strong enough, adjust the work holder presser as follow .

(1) Insert the sewing material①under the work holder②.

(2) Turn the power switch ON and lower the work holder②with the work holder foot switch

(3) Loosen the 2 of the setscrews③and move adjusting plate④until it touches the material①then, tighten the 2 of the setscrews③.

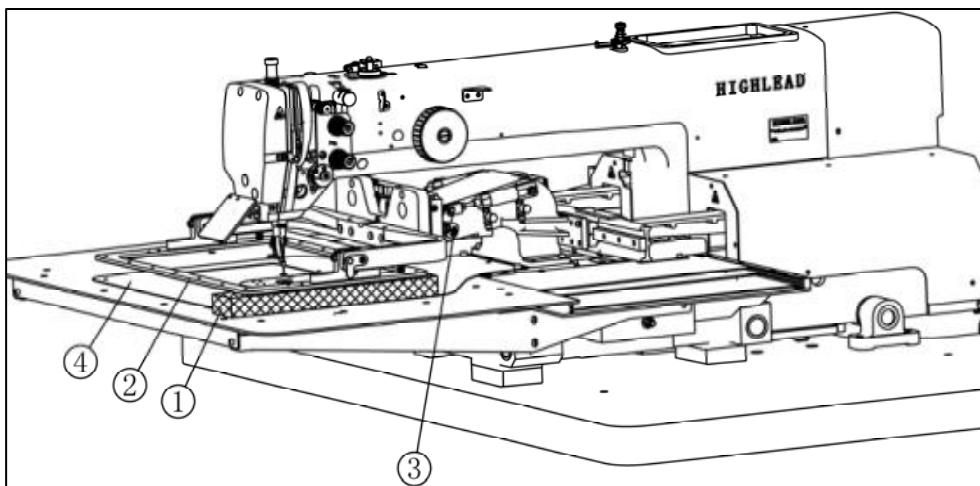

7-10 Adjustment of the trimmer cam follower

- (1) Turn the power switch OFF and remove the top cover.
- (2) Under the sewing machine regular stop condition (the needle stop position is upper and the take up lever stop position is highest), loosen the setscrew ⑤ of the cam follower lever ④ and adjust the cam follower ② to be positioned to contact with the shoulder portion ③ of the trimmer cam ① with having about 1 mm clearance between the cam follower ② and the trimmer cam ①. After this adjustment, tighten the setscrew ⑤ of the cam follower lever ④.
- (3) Push the cam follower lever ④ by hand to the arrow direction and make sure that the cam follower ② is engaged into the cam groove ③ smoothly.

- (4) If the cam follower ② is not engaged smoothly, under confirming with the condition which the cam follower ② contacts with the shoulder portion ③ of the trimmer cam ①, loosen the nut ⑦ and tighten the stopper screw ⑧ until it touches with the stopper ⑨ of the cam follower lever ④ then, loosen the stopper screw ⑧ back about 1/3 turn and fix the nut ⑦ firmly.

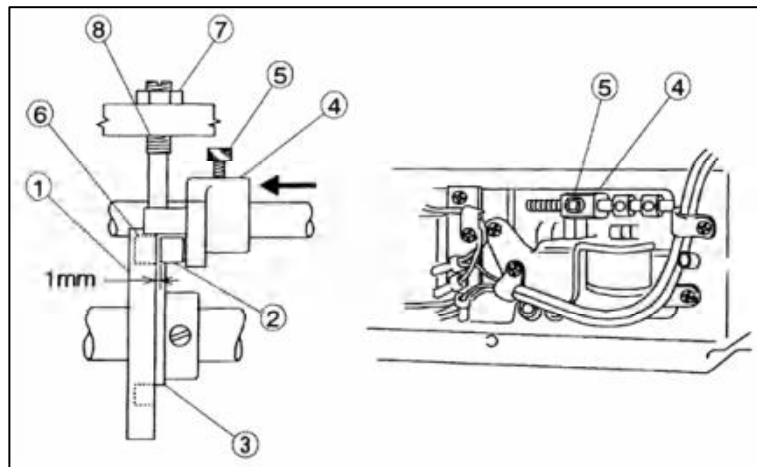

7-11 Adjustment of the position for the movable knife point

- (1) Tilt the sewing machine head to the left to be able to see the bottom component parts.
- (2) Open the cylinder cover
- (3) Check with the point ① of the movable knife whether it is located at the position apart 0.5mm from the front face of the hook retainer ②.
- (4) For the adjustment of the movable knife point ①, loosen the adjusting screw ③ and move the rod end ④ right and left then, adjust the position of the movable knife point.
- (5) After the adjustment, tighten the adjusting screw nut ③ securely.

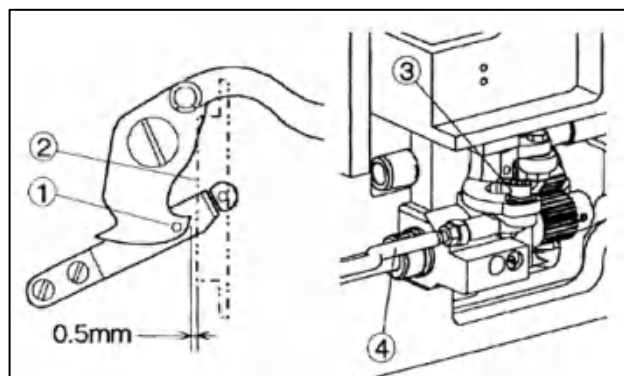

7-12 Adjustment of the fixed knife position

- (1) Open the cylinder cover①.
- (2) Remove the E-shaped snap ring④, which engages the movable knife②and the link③.
- (3) Loosen the setscrews⑤then, remove the sliding plate⑥.
- (4) Turn the sliding plate⑥upside down and loosen two setscrews⑨then, adjust the fixed knife ⑩ position to be positioned for the blade edge⑦to have the clearance 0.5mm from the edge of the needle plate⑧.

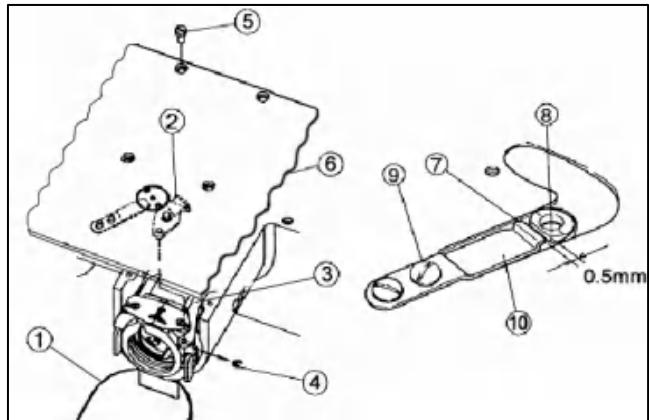

- (5) After the adjustment, tighten the setscrews⑨securely.
- (6) Put all the parts for this adjustment back to the original locations.

7-13 Adjustment of the thread take up spring swing stroke

Loosen the setscrew②and turn the whole thread tension regulator③then, adjust the thread take up spring swing stroke to be become 9 to 10mm.

After the adjustment, tighten the setscrew②securely.

7-14 Adjustment of the thread take up spring tension

Insert the screw driver⑤into the slit④of the thread tension regulator③and adjust the thread take up spring①tension. If turn the screw driver to the clockwise, the thread take up spring tension becomes tight. and if turn the screw driver to the counter clockwise. the thread take up spring tension becomes loose.

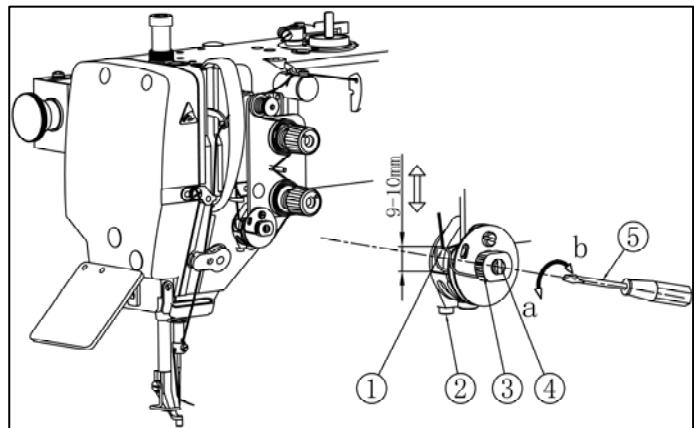

7-15 Adjustment of the thread tail after the trimming

Adjust the thread tail③from the needle after the trimming with turning the nut ② of the pre-tension①.

If turn the nut②to the clockwise, the thread tail becomes shorter and if turn the nut②to the counter-clockwise, the tread tail becomes longer.

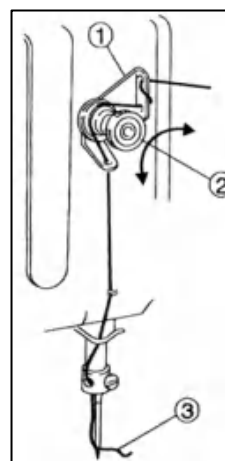

7-16 Cancellation of the trimming function

If the automatic trimming is not required during the sewing operation ,cancel the Trimming function with the setting panel of the control box .

7-17 Adjustment of the upper thread tension release

- [NOTE] (a) The upper thread tension release works when the upper thread is trimmed automatically or the presser foot is lifted during the work holder feeding.
- (b) If the upper thread tension release does not work properly when the upper thread is trimmed automatically, the thread tail from the needle becomes shorter then, it induces the skip stitch happening or pulling the thread tail out of the needle at the start of the sewing.
- (c) During the sewing operation, the discs① of the thread tension regulator is closed while the presser foot is moving up and down.
If the discs① of the thread tension regulator is not closed, the upper thread tension becomes loose and the proper stitch condition can not be obtained.
- (d) When the upper thread tension release is activated, the discs① the upper thread tension regulator opens 0.8~1.0mm. This is the normal conduction of the discs① opening. For this adjustment, take the following procedure.

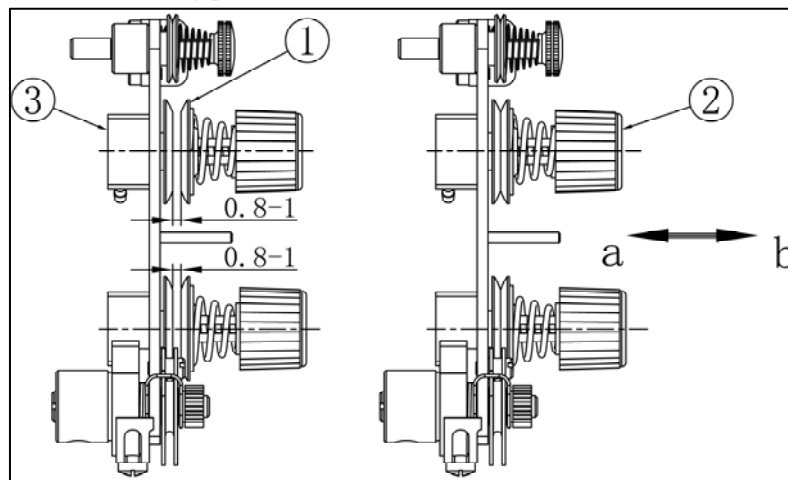

- (1) Remove the top motor cover.
- (2) Fully turn the crank③of the rotary solenoid②in the arrow direction. At this time,
- (3) adjust the upper thread tension release for the discs to be opened 0.8 to 1.0 mm. For this adjustment, loosen the nut “a” then, if tighten the nut “b”, the discs opening becomes wider and if loosen the nut “b”, it becomes narrower.
- (4) If the normal opening of the discs can not be obtained with the nut adjustment, loosen the wire fix screws and adjust the tension of the wire .
- (5) The wire may be got longer over a long period machine operation. At that time, adjust the upper thread tension release again.

7-18 Adjustment of the mechanical home position

[NOTE]The mechanical home position is fixed at the center of the sewing area when the sewing machine is shipped from the factory. However, it can be moved within the area covered with diagonal lines.

- (1) Turn the power switch ON and cancel the sewing area limit with the operation panel.
- (2) After the cancellation of the sewing area limit, once. Turn the power switch OFF.

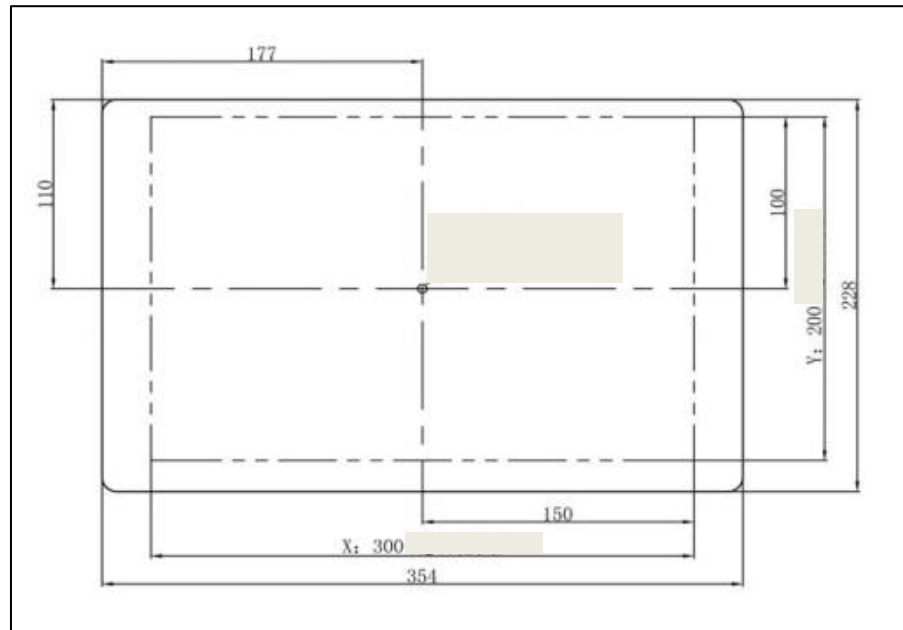

7-18.1 Shifting the mechanical home position to the X direction

- (1) Remove the X-Y cover (right),(left) and X cover.
- (2) Loosen the detector plate fix screws(2 pieces) ①. if move the detector plate② to the right, the mechanical home position is shifted to the left and if it is moved to the left, the mechanical home position is shifted to the right.
- (3) After the mechanical home position setting, tighten the detector plate fix screws ① securely.

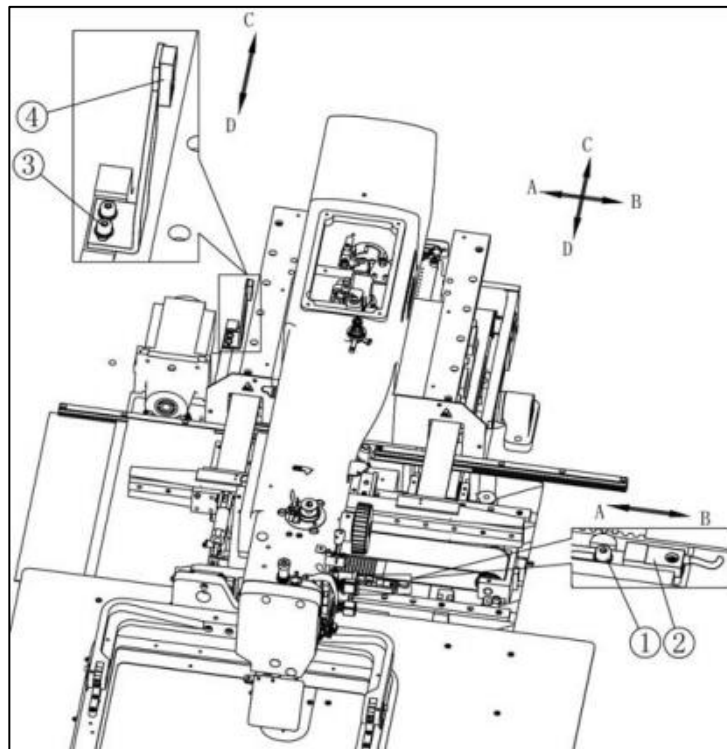

[NOTE] When the original mechanical home position is shifted. Please check the clearance between the X detector plate and the X detector. This clearance should be set within the range of 1.0—1.5 mm.

7-18.2 Shifting the mechanical home position to the Y direction

- (1) Loosen the Y-detector setscrew③.
- (2) If move the Y-detector④to the front, the mechanical home position is shifted to the backward. If it is moved to the backward. the mechanical home position is shifted to the front.
- (3) After the mechanical home position setting, tighten the screw③securely.

8 MAINTENANCE

Caution

- ★Please make sure to turn the power switch always OFF when clean up the sewing machine.
- ★Before or after the sewing operation, clean up the sewing machine and check the Oil level in the oil tank.

8-1 Cleaning

- (1) Turn the power switch OFF.
- (2) Remove the dust and the thread waste sticking around the threading parts or the shuttle hook area.
- (3) Check the oil level in the oil tank. If the oil is under the red mark level supply the oil to be over the red mark level.
- (4) If the waste oil is full, please remove the oil .

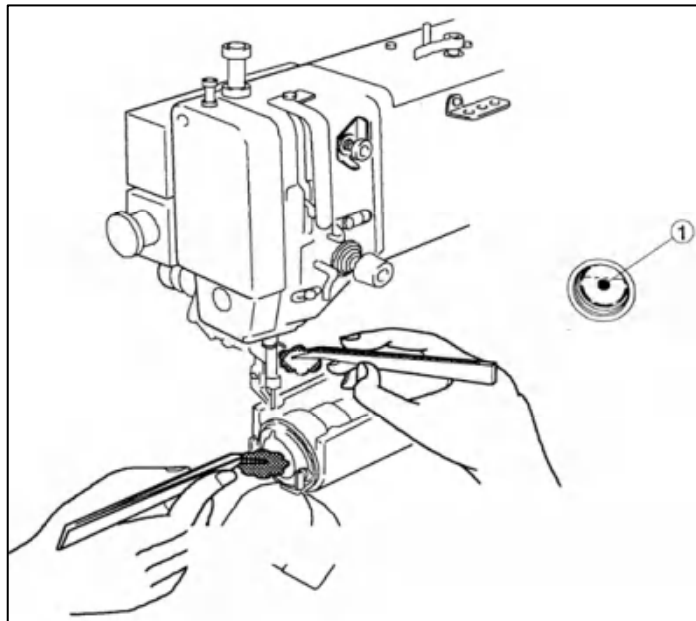

9 BAD SEWING CONDITION & ITS CAUSE AND REMEDY

[NOTE] Please fix the troubles during the sewing machine operation with referring to the following instructions. Beside, if the trouble conditions are not coming under these classification, please contact the sewing machine dealers nearby.

Bad condition	Cause	Remedy	Ref. page & item
1. Upper thread breakage after happens	Poor thread tension	Use better quality thread	—
	Tight upper thread tension	Adjust thread tension	6-3
	Strong thread take up spring	Adjust thread take up spring properly	7-14
	Upper thread is thicker than needle size	Change needle to suitable size	—
	Damages on shuttle hook or drive	Change them new ones or grind them with buffing wheel or grind stone	—
	Damages inside presser foot needle hole	Change it new one or grind it with buffing wheel	—
	Needle touches with presser foot needle hole	Move presser foot position	7-6-1(6)
	Needle and shuttle hook are not in proper timing	Adjust the timing	7-2
	Thread melts with needle heat	Slow down sewing speed	—
		Use silicon oil	—
Use needle cooler		—	
2. Upper thread is pilled out from needle	Thread tension discs are not opened at trimming	Adjust thread tension release	7-17
	Thread take up spring swings too much	Adjust thread take up spring's swing stroke	7-14
	Upper thread is broken before regular trimming	Adjust fixed knife and needle plate position	7-12
	Needle size is bigger than thread size	Change needle to suitable size	—
	Pre-tension is too tight	Adjust pre-tension	7-16
	Thread guide is in wrong position	Adjust thread guide position properly	7-5
	Needle and shuttle hook are in bad timing	Adjust the timing properly	7-2
	Trimmer timing is not correct	Adjust trimmer cam position	7-10
		Adjust movable knife position	7-11
Adjust synchronizer position		—	

Bad condition	Cause	Remedy	Ref. page & item
3. Skip stitch happens at start sewing	Too short bobbin thread by bobbin spinning after trimming	Use non racing spring with bobbin	—
	Bobbin thread tension is too tight	Loosen bobbin thread tension spring	6-3
	Thread tail from needle is very short after trimming	Decrease pre-tension	7-16
		Adjust trimmer cam position	7-10
		Adjust synchronizer position	—
		Make thread take up swing stroke smaller	7-13
		Advance thread tension release timing	Control unit
Adjust thread guide position properly	7-5		
4. Thread tail from needle is too long after trimming	Pre-tension is too loose	Make pre-tension tighter	7-14
	Trimmer timing is delayed	Adjust trimmer cam position	7-10
		Adjust synchronizer position	—
	Upper thread tension release timing is too fast	Delay tension release timing	Control unit
Tread guide is in wrong position	Adjust thread guide position properly	7-5	
5. Trimming is not functioned	Trimmer function is canceled	Resume trimmer function	Control unit
	Fixed knife is dull	Change it new knife	7-11
	Movable Knife is in wrong position	Adjust movable knife position properly	7-11
	Skip stitching happens at trimming	Fix skip stitching	7-6
	Trimmer timing is wrong	Adjust trimmer cam position	7-10
Adjust synchronizer position		—	
6. Skip stitching often happens	Needle and shuttle hook clearance is too big	Adjust needle and shuttle hook timing properly	7-2
	Needle and shuttle hook timing is not correct	Adjust needle and shuttle hook timing properly	7-2
	Needle is bent	Change it new needle	—
	Needle is bent by driver	Adjust needle and diver clearance properly	7-4
	Needle is in wrong position	Amend needle position	7-2
	Presser foot position is not correct	Adjust presser foot position properly	7-6

Bad condition	Cause	Remedy	Ref.page & item
7. Stitch forming is loose	Upper thread tension is not tight enough	Increase upper thread tension	6-3
	Thread tension regulator's discs are opened during sewing	Adjust tension regulator position properly	7-17
		Adjust upper tension release position properly	7-17
	Presser foot position is not correct	Adjust presser foot position properly	7-6
	Driver and shuttle hook clearance is very small	Change shuttle hook	—
	Presser foot up and down timing is not proper	Adjust presser foot timing properly	7-6
8. Sewing machine does not work even start switch is turned ON	Cables wiring is disconnected	Connect all cables precisely	3
	System software is not loaded	Load system software to control box	5-1
	Emergency stop switch is kept ON	Release emergency stop switch lock	6-1
9. Sewing machine runs idle at high speed when power switch is turned ON	Synchronizer cable is disconnected	Connect synchronizer cable precisely	control unit
	Synchronizer is out of order	Change it new synchronizer	—
10. Work holder does not work	Work holder activate cable is disconnected	Connect the cable precisely	control unit
	Work holder activate cable is not strong enough	Increase work holder pressure	7-9
	Work holder switch is out of order	Change it new work holder switch	—
11. Sewing pattern is distorted	Work holder switch is not strong enough	Increase work holder pressure	7-9
	sewing material weight is very heavy	Slow down sewing speed	6-2
		Slow down feeding speed	control unit
		Select sewing material weight level at feeding	control unit
X timing belt is loose	Adjust X timing belt tension properly	7-21	

Bad condition	Cause	Remedy	Ref. page & item
12. Work holder does no stop at home position	X-Y detectors cable are disconnected	Connect X-Y cables precisely	—
	X-Y detectors cable are out of order	Change them new detectors	—
	Detector and detector plate clearance is too big	Adjust the clearance properly	7-19
13. Work holder stops at not original home position	Detector and detector plate mounting is loose	Check setscrews and tighten them securely	7-19
	Detector and detector plate clearance is bigger than standard	Adjust detector and detector plate clearance properly	7-19

A. ARM BED & IT' S ACCESSORIES (一)

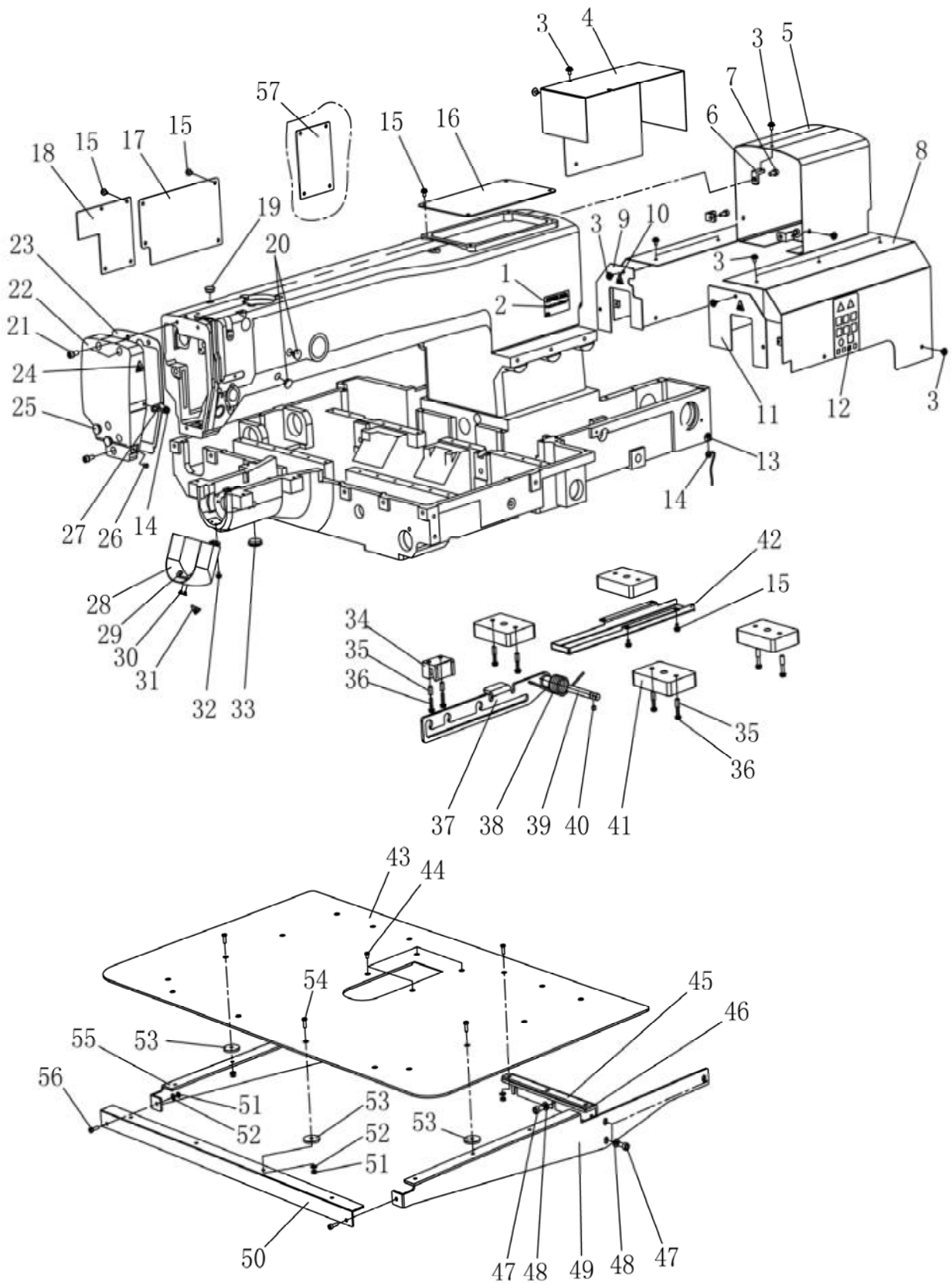

A. ARM BED & IT'S ACCESSORIES (一)

序号	样本编号	名 称	数量	备 注
A01	HN71B48001	Type plate	1	
A02	H924025050	Pin	2	
A03	H6697F8001	Screw	21	M4×8
A04	HN71B58001	X motor cover	1	
A05	HN73B28001	Motor cover	1	
A06	HN73B38001	Motor shelf	3	
A07	H6692D8001	Screw	3	M5×12
A08	HN71B68001	Y Motor cover	1	
A09	HN71B88001	Rear cover (left)	1	
A10	HA300B2240	Injury mark	2	
A11	HN71B78001	Rear cover (right)	1	
A12	HA300B2250	Notice mark	1	
A13	HA300B2220	Earthing wire mark	3	
A14	H6601B8001	Screw	2	M4×6
A15	H6642B8001	Screw	19	M4×8
A16	HN72B28001	Cover plate	1	
A17	HN71B98001	Cover plate	1	
A18	HN74B38001	Cover plate	1	
A19	H4715B8001	Rubber plug	1	
A20	HA307B0674	Rubber plug	2	
A21	H6692D8001	Screw	3	M5×12
A22	HA17901-69	Panel	1	
A23	HA17901-71	Gasket	1	
A24	HA300B2240	Injury mark	1	
A25	HA307B0674	Rubber plug	2	
A26	HA106B0676	Screw	1	9/64 (40) ×6
A27	HA17901-70	Thread guide	1	
A28	H663FB7101	Cylinder cover	1	
A29	H6691B8001	Spring	1	
A30	H6692B8001	Screw	2	9/64 (40) ×3.2
A31	H6697B8001	Injury mark	1	
A32	H6698B8001	Screw	4	M3×6
A33	HA307B0673	Rubber plug	1	
A34	HN72B78001	Rubber plug	1	
A35	HN72B58001	Washer	10	
A36	H6609I8001	Screw	10	M4×20
A37	HN72B87101	Support lever	1	
A38	HN73B08001	spring	1	
A39	HN71K08001	Support lever shaet	1	
A40	H431060060	Screw	1	M6×6
A41	HN72B48001	Cushion	4	
A42	HN73B18001	Oil pan	1	
A43	HN71G18001	Auxiliary plate	1	

A. ARM BED & IT'S ACCESSORIES (一)

序号	样本编号	名 称	数量	备 注
A44	H6623C8001	Screw	4	M4×8
A45	HN71G88001	Gasket	2	
A46	HN71G78001	Bracket	2	
A47	H415060120	Screw	12	M6×12
A48	H005001060	Washer	12	
A49	HN71G58001	Bracket	1	
A50	HN71G68001	Bracket	1	
A51	H003002040	Nut	18	M4
A52	H005001040	Washer	18	
A53	HN71G38001	Rubber washer	10	
A54	H416040120	Screw	16	M4×12
A55	HN71G48001	Bracket	1	
A56	H669DE8001	Screw	2	M4×12
A57	HN72B18001	Cover plate	1	peculiar order

B. ARM BED & IT' S ACCESSORIES (二)

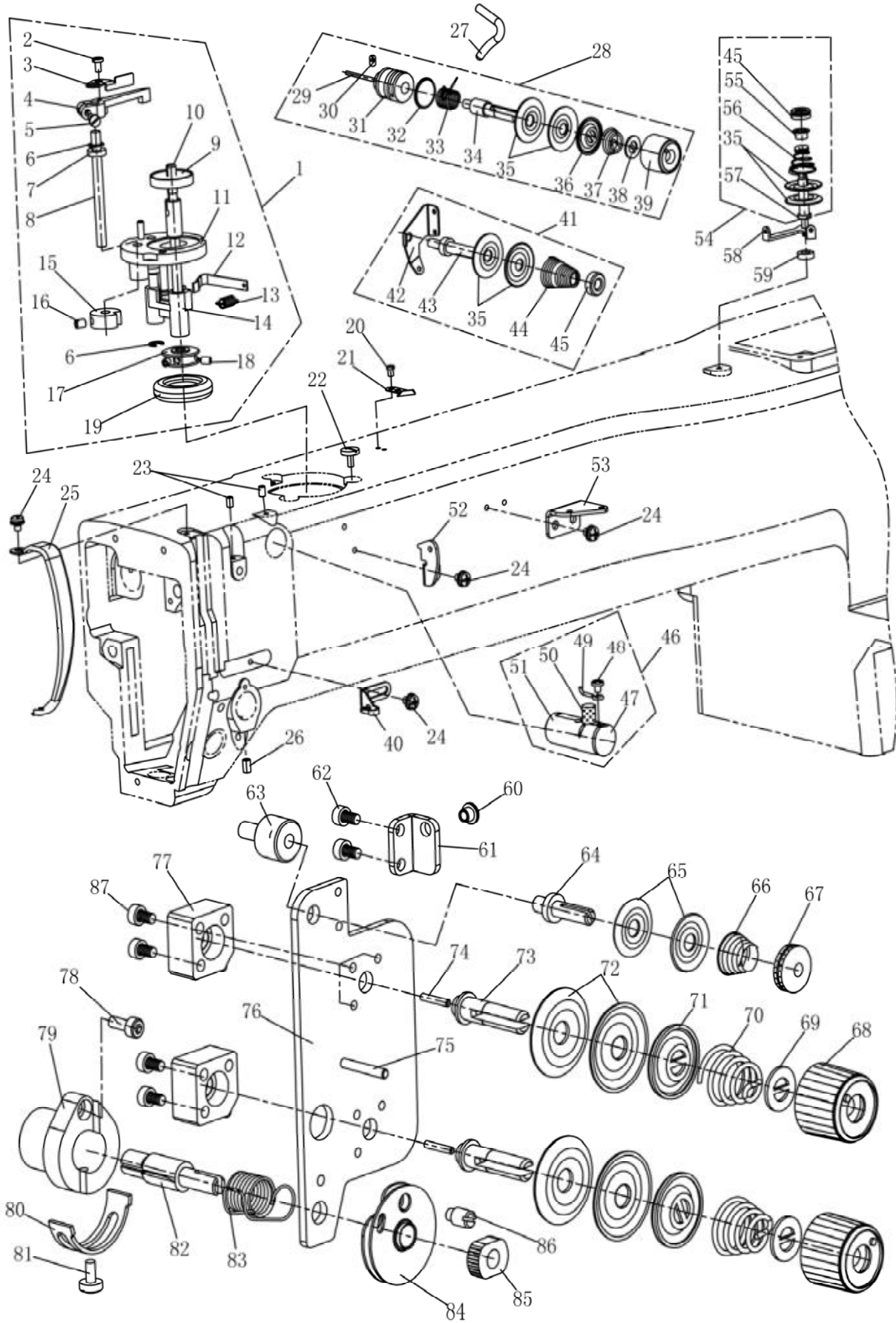

B. ARM BED & IT'S ACCESSORIES (二)

序号	样本编号	名 称	数量	备 注
B01	HN74B07101	Reel wire implement	1	
B02	H3200B2100	Screw	1	9/64 (40) × 6.5
B03	HA17901-61	Full wire plate	1	
B04	H6720N8001	Lever	1	
B05	HA100H2150	Screw	1	9/64 (40) × 11
B06	H007013050	E-type retaining ring	2	
B07	H6722N8001	Washer	1	Φ12 × Φ6 × 3
B08	HA17901-64	shaft	1	
B09	HA17901-60	Bobbin support	1	
B10	HA17901-59	Bobbin winder shaft	1	
B11	H6705N7101	Bobbin winder platform	1	
B12	H6715N8001	Plate spring	1	
B13	H6724N8001	Spring	1	
B14	H6711N7101	Bobbin winder lever	1	
B15	H6725N8001	Cam	1	
B16	H431050060	Screw	1	M5 × 6
B17	H6718N8001	Wheel	1	
B18	H431040060	Screw	2	M4 × 6
B19	H6719N8001	Tire	1	
B20	H6762B8001	Screw	2	SM9/64 × 40/4.5
B21	H6756B8001	Knife	1	
B22	H3107G0662	Screw	3	9/64 (40) × 8
B23	H431040060	Screw	2	M4 × 6
B24	H660IB8001	Screw	4	M4 × 6
B25	HA17901-93	Thread take-up lever guard	1	
B26	H431050100	Screw	1	M5 × 10
B27	H3000B2130	Thread guide	1	peculiar order
B28	HA17902-75	Splint string assembly	1	peculiar order
B29	HA115B0709	Pin	1	
B30	HA115B0708	Screw	1	9/64 (40) × 4.5
B31	HA310B0703	Regulator casing	1	
B32	HA115B7011	O ring	1	
B33	HA115B0706	Thread take-up spring	1	
B34	HA115B0701	Screw	1	1/4 (40)
B35	HA310B0705	Thread tension discs	6	
B36	HA310B0702	Disc retaining plate	1	
B37	H6675C8001	Thread tension spring	1	
B38	HA115B7010	Thumb nut revolution stopper	1	
B39	HA310B0701	Thumb nut	1	
B40	HA600B2050	Thread guide	1	
B41	HA17902-71	Splint string module	1	peculiar order
B42	HA17902-74	Thread guide	1	
B43	HA17902-73	Thread tension stud	1	1/4(40)

B. ARM BED & IT'S ACCESSORIES (二)

序号	样本编号	名 称	数量	备 注
B44	HA17902-72	Thread tension spring	1	
B45	H660GB8001	Thumb nut	2	
B46	HN71C67101	Needle cooler seat	1	
B47	HN71C78001	Oil gauge	1	
B48	H6692B8001	Screw	1	9/64 (40) × 3.2
B49	HN71C58001	Thread guide	1	
B50	HN71C48001	Felt	1	Φ8×15.5
B51	HN71C38001	Needle cooler seat	1	
B52	HA17902-80	Thread guide	1	
B53	HA17902-79	Thread guide	1	
B54	H660DB7101	Splint string module	1	
B55	H660FB8001	Spring guide	1	
B56	H660EB8001	Thread tension spring	1	
B57	H660HB8001	Thread tension stud	1	
B58	H6662B8001	Thread guide	1	
B59	H6663B8001	Spacer	1	
B60	H3221B0681	Prcelain pipe	1	
B61	HN75C28001	Thread guide	1	
B62	H415030050	Screw	2	M3×5
B63	HN75C08001	Pad piece	1	
B64	H3221B0683	Thread tension stud	1	
B65	HA112B0693	Tension board	2	
B66	H3221B0684	Thread tension spring	1	
B67	HA710B0671	Thumb nut	1	
B68	HA310B0701	Thumb nut	2	
B69	HA115B7010	Thumb nut revolution stopper	2	
B70	HA115B0703	Tension spring	2	
B71	HA310B0702	Disc retaining plate	2	
B72	HA310B0705	Thread tension discs	4	
B73	H3221B0686	Thread tension stud	2	
B74	HFC1258001	Tension release pin	2	
B75	H3221B0682	pin	1	
B76	HN74C98001	Install plate	1	
B77	HFC1048001	Cylinder	2	
B78	H415030080	Screw	1	M3×10
B79	HN75C18001	Bushing	1	
B80	H32481BB21	baffle	1	
B81	H32481BC21	Screw	1	
B82	H4805C8001	Screw	1	
B83	H4713C8001	spring	1	
B84	H32481BD21	Thread guide	1	
B85	H32481B721	Nut	1	
B86	H4804C8001	Screw	1	

B. ARM BED & IT'S ACCESSORIES (二)

序号	样本编号	名 称	数量	备 注
B87	H415030080	Screw	6	M3×10

C. SEWING MECHANISM (一)

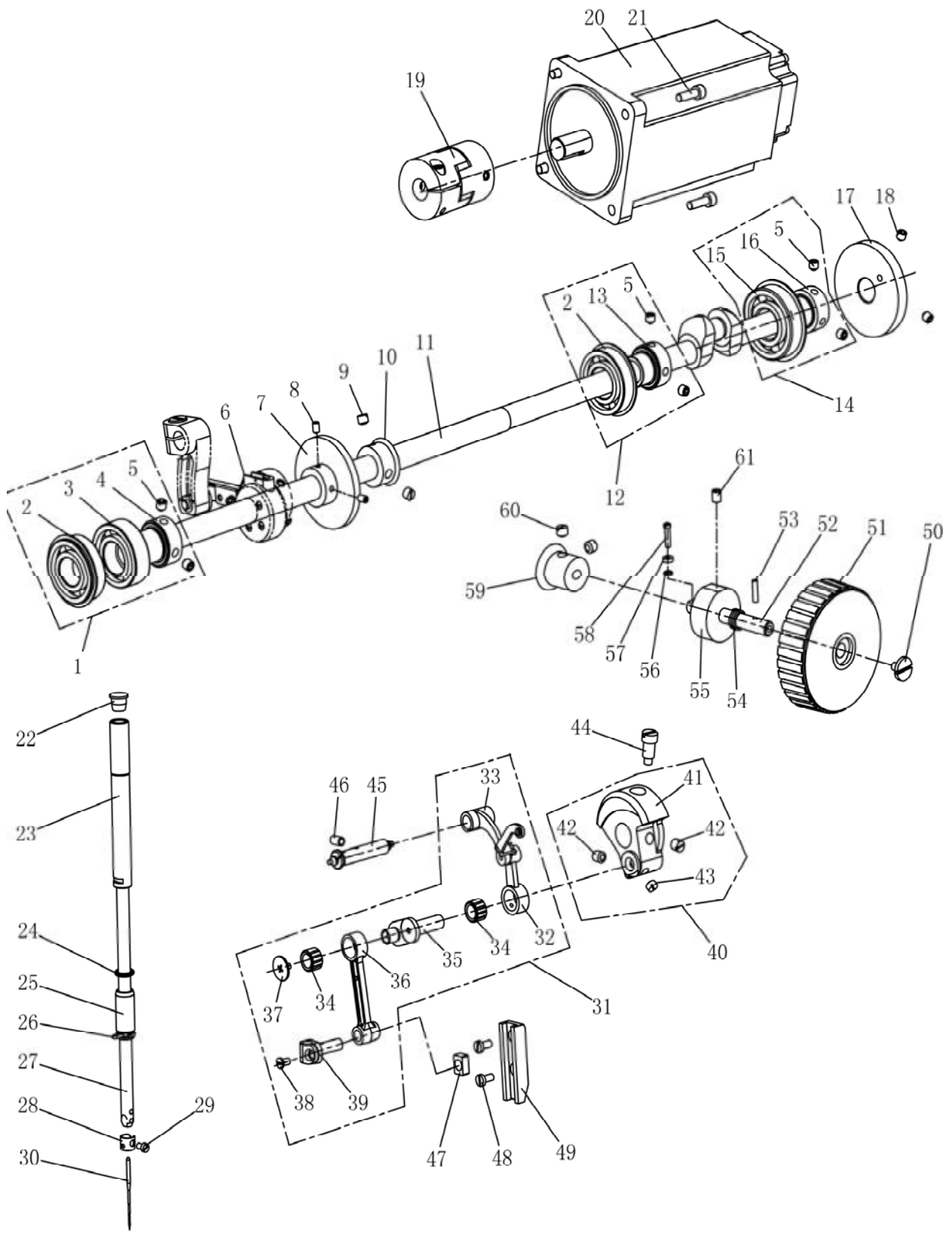

C. SEWING MECHANISM (一)

序号	样本编号	名 称	数量	备 注
C01	HA17901-16	Bearing module	1	
C02	H3208H0661	Bearing	2	B6004ZZNR D42/d20/B12
C03	H8812D8001	Bearing	1	B6004ZZ D42/d20/B12
C04	HA17901-17	Bushing	1	
C05	H431060080	Screw	6	M6×8
C06	HA17905-02	connecting rod	1	
C07	H6608C8001	Pulley	1	
C08	H431040060	Screw	2	M4×6
C09	HA307C0662	Screw	2	SM1/4(40)×5
C10	HY507D8001	Gear	1	
C11	HN70C48001	Drive shaft	1	
C12	HA17901-22	Bearing module	1	
C13	HA17901-23	Bushing	1	
C14	HA17901-25	Bearing module	1	
C15	H3205J0662	Bearing	1	B6204ZZNR D47/d20/B12
C16	HA17901-26	Bushing	1	
C17	H6606F8001	Cam	1	
C18	HA105D0662	Screw	2	1/4(40)×4
C19	HN71C07101	Coupling	1	
C20	HN71C98001	Motor	1	750W:337P5003A
C21	HA19041855	Screw	4	M5×16
C22	HA300B2090	Rubber plug	1	
C23	HA17901-09	Needle bar bushing(upper)	1	
C24	H6632B8001	O ring	1	
C25	HA17901-10	Needle bar bushing(lower)	1	
C26	HA300C2070	Thread guide	1	
C27	H6624C8001	Needle bar	1	
C28	H6625C8001	Thread guide	1	
C29	HA100C2170	Screw	1	1/8(44)×4.5
C30	JZDP1700G1801	needle	1	
C31	HA17902-08	Thread take-up lever assy	1	
C32	HA17902-09	Thread take-up lever assy	1	
C33	HA17902-14	Crank	1	
C34	HA104C0655	bearing	2	
C35	HA17902-11	Crank	1	
C36	HA17902-12	Crank	1	
C37	H6715I8001	Screw	1	
C38	H2204C0651	Screw	1	9/64(40)×6.5
C39	HA104C0658	Needle bar joint	1	
C40	HA17902-04	Crank module	1	
C41	HA17902-05	Crank	1	
C42	HA307C0662	Screw	2	1/4(40)×6
C43	HA105D0662	Screw	1	1/4(40)×4

C. SEWING MECHANISM (一)

序号	样本编号	名 称	数量	备 注
C44	HA100C2070	Screw	1	9/32 (28) × 10
C45	HA17902-15	Shaft module	1	
C46	H431050080	Screw	1	M5 × 8
C47	HA100C2200	Square block	1	
C48	H6623C8001	Screw	2	M4 × 8
C49	H6622C8001	Slide block guide	1	
C50	H5311F8001	Screw	1	11/64 (40) × 6.1
C51	HK42C98001	Hand wheel	1	
C52	HA15401-15	Shaft	1	
C53	H609030120	Pin spring roll	1	
C54	H4767E8001	Spring	1	
C55	HA15401-16	Bushing	1	
C56	HA15401-12	Washer	1	
C57	HA15401-14	Bearing	1	
C58	HA15401-13	Screw	1	M3 × 10
C59	HY508D8001	umbrella gear	1	
C60	HA108C0662	Screw	2	1/4 (40) × 5
C61	H431050060	Screw	1	M5 × 6

D. SEWING MECHANISM (二)

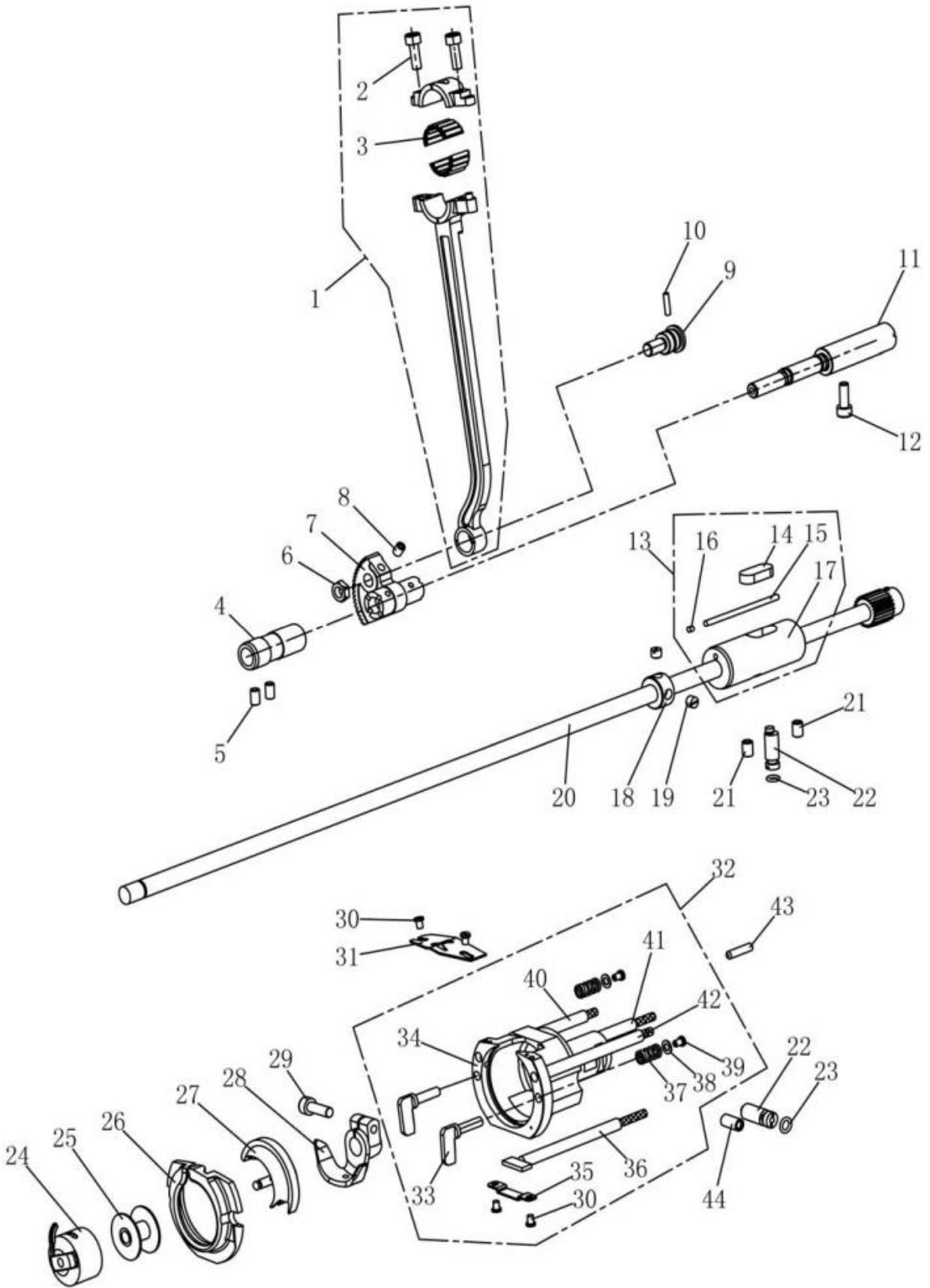

D. SEWING MECHANISM (二)

序号	样本编号	名 称	数量	备 注
D01	HA17902-33	Connecting rod assy	1	
D02	H6676E8001	Screw	2	M5×14
D03	HA17902-48	Bearing	1	
D04	HA17901-37	Bushing	1	
D05	H431050080	Screw	2	M5×8
D06	H2010J0066	Nut	1	9/32(28)
D07	H6631C8001	Sector gear	1	
D08	H431050060	Screw	1	M5×6
D09	HA17902-38	Screw	1	9/32×28
D10	HA17902-39	Wool rope	1	
D11	HA17902-41	Rock shaft	1	
D12	H415050100	Screw	1	M5×10
D13	HN71B17101	Bushing	1	
D14	HA17901-33	Felt	1	
D15	HA17901-34	Oil braid	1	
D16	HA17901-35	Rubber plug	1	
D17	HN71B28001	Bushing(back)	1	
D18	H6670C8001	Collar	1	
D19	HA305E0662	Screw	2	15/64(28)×4.5
D20	HN71C17101	Hook shaft assy	1	
D21	H431060080	Screw	2	M6×8
D22	H6648C8001	Bias axle	2	
D23	H6632B8001	O ring	2	
D24	H6684C8001	Bobbin case(big)	1	
D25	H6685C8001	Bobbin (big)	1	
D26	H6674C8001	Hook retaine	1	
D27	H6683C8001	Shuttle hook	1	
D28	H6654C8001	Hook driver	1	
D29	HA19041855	Screw	1	M5×16
D30	H6658C8001	Screw	4	1/8(40)×4
D31	H6657C8001	Thread guide	1	
D32	HA17902-51	Shuttle race assy	1	
D33	H6646C8001	Hook clamp	2	
D34	HA17902-52	Outer hook	1	
D35	HA17902-66	Holder	1	
D36	HA17902-62	Oil pipe assy	1	
D37	H6645C8001	Spring	2	
D38	H6644C8001	Washer	2	
D39	H6643C8001	Screw	2	1/8(44)×4.5
D40	HA17902-53	Oil pipe assy(left)	1	
D41	HA17902-59	Oil pipe assy(centre)	1	
D42	HA17902-56	Oil pipe assy(right)	1	
D43	H6651C8001	Pin	1	

D. SEWING MECHANISM (二)

序号	样本编号	名 称	数量	备 注
D44	H431060120	Screw	1	M6×12

E. X-Y TABLE MECHANISM (一)

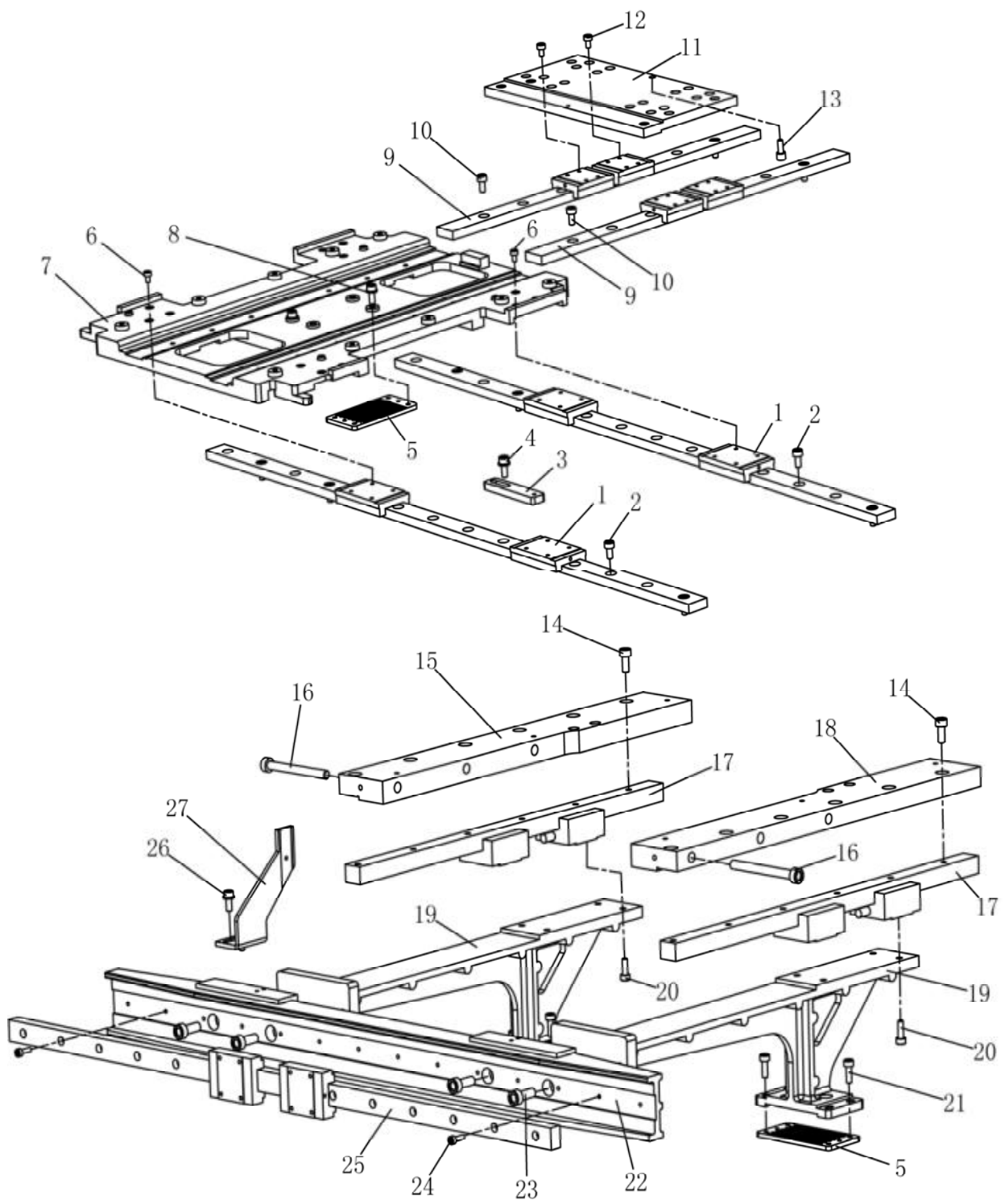

E. X-Y TABLE MECHANISM (一)

序号	样本编号	名 称	数量	备 注
E01	HN73D57101	X slide guide	2	SHW12HRM
E02	H415040080	Screw	22	M4×8
E03	HN76D08001	Detector X mounting plate	1	
E04	H6696F8001	Screw	1	M4×10
E05	HN74D68001	Belt clamper	3	
E06	H415030060	Screw	16	M3×6
E07	HN73D68001	Movable race X	1	
E08	H6696F8001	Screw	4	M4×10
E09	HN73D77101	Y slide guide	2	SHW12CRM
E10	H415040080	Screw	14	M4×8
E11	HN73D87101	Movable race Y	1	
E12	H415030060	Screw	16	M3×6
E13	H415050060	Screw	1	M5×5
E14	H415050120	Screw	12	M5×12
E15	HN74D58001	Y slide guide bracket(L)	1	
E16	H415060600	Screw	6	M6×60
E17	HN74D37101	Y slide guide	2	SSR15XVY-K
E18	HN74D48001	Y slide guide bracket(R)	1	
E19	HN74D18001	Y arm assy	2	
E20	H669DE8001	Screw	8	M4×12
E21	H669DE8001	Screw	8	M4×12
E22	HN74D08001	Y arm	1	
E23	H415060160	Screw	4	M6×16
E24	H415030140	Screw	14	M3×14
E25	HN73D97101	X slide guide	1	SRS15M
E26	H6696F8001	Screw	2	M4×10
E27	HN76D38001	Detector Y mounting plate	1	

F. X-Y TABLE MECHANISM (二)

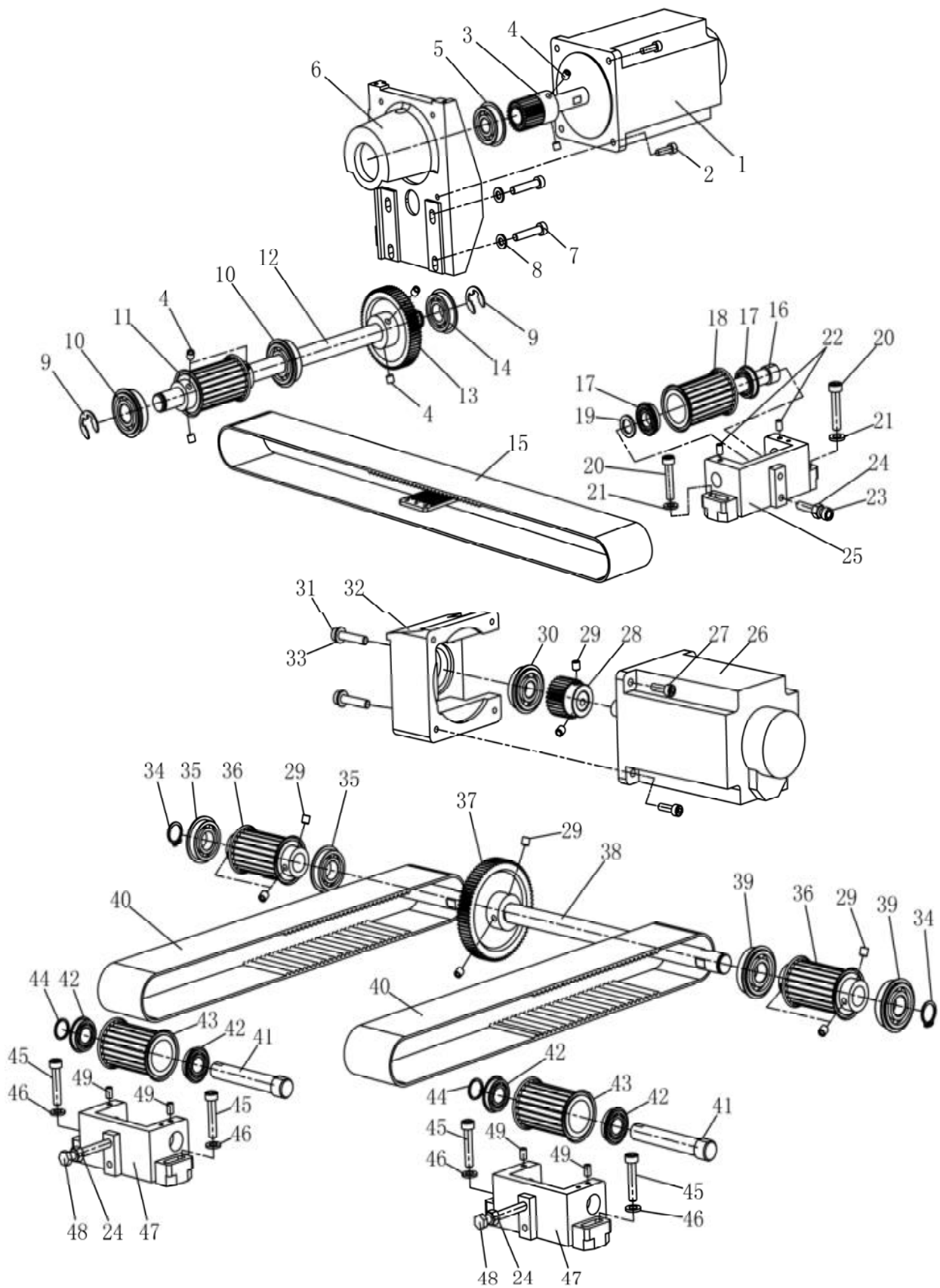

F. X-Y TABLE MECHANISM (二)

序号	样本编号	名 称	数量	备 注
F01	HN72D68001	Motor X	1	
F02	H415050160	Screw	4	M5×16
F03	HN72D18001	Gear X(small)	1	m=1, z=24
F04	H431060060	Screw	10	M6×6
F05	HN72D28001	Bearing	1	B6201ZZNR (D32/d12/B10)
F06	HN72D38001	Motor bracket X	1	
F07	HS90329130	Screw	4	M6×30
F08	H005001060	Washer	4	
F09	H007013120	E-type retaining ring	2	
F10	HN71D28001	Bearing	2	B6202ZZNR (D35/d15/B11)
F11	HN71D48001	Driving pulley B	1	5GT (22)
F12	HN71D58001	Driving shaft X	1	
F13	HN71D78001	Gear X(big)	1	m=1, z=66
F14	HN71D88001	Bearing	1	B6002ZZNR (D32/d15/B9)
F15	HN71D18001	Cog belt X	1	1080-5GT-50
F16	HN70D98001	Pulley shaft X	1	
F17	HN70D88001	Bearing	2	B6901ZZNR (D24/d12/B6)
F18	HN70D78001	Driving pulley A	1	5GT (22)
F19	HN71D08001	retaining ring	1	
F20	HS90329130	Screw	2	M6×30
F21	H005001060	Washer	2	
F22	H431050080	Screw	2	M5×8
F23	H415060400	Screw	1	M6×40
F24	H003001060	Nut	3	M6
F25	HN70D68001	Bracket	1	
F26	HN73D08001	Motor Y	1	
F27	H415050160	Screw	4	M5×16
F28	HN73D48001	Gear Y(small)	1	m=1, z=28
F29	H431060060	Screw	14	M6×6
F30	HN72D28001	Bearing	1	B6201ZZNR (D32/d12/B10)
F31	H415060250	Screw	4	M6×25
F32	HN72D98001	Motor bracket Y	1	
F33	H005001060	Washer	4	
F34	H007009150	retaining ring	2	
F35	HN71D88001	Bearing	2	B6002ZZNR (D32/d15/B9)
F36	HN71D48001	Driving pulley B	2	5GT (22)
F37	HN76D68001	Gear Y(big)	1	m=1, z=77
F38	HN72D78001	Driving shaft Y	1	
F39	HN71D28001	Bearing	2	B6202ZZNR (D35/d15/B11)
F40	HN72D58001	Cog belt Y	2	800-5GT-50
F41	HN70D98001	Pulley shaft X	2	
F42	HN70D88001	Bearing	4	B6901ZZNR (D24/d12/B6)
F43	HN70D78001	Driving pulley A	2	5GT (22)

F. X-Y TABLE MECHANISM (二)

序号	样本编号	名 称	数量	备 注
F44	HN71D08001	retaining ring	2	
F45	HS90329130	Screw	4	M6×30
F46	H005001060	Washer	4	
F47	HN70D68001	Bracket	2	
F48	H104060550	Bolt	2	M6×55
F49	H431050080	Screw	4	M5×8

G. X-Y TABLE MECHANISM (三)

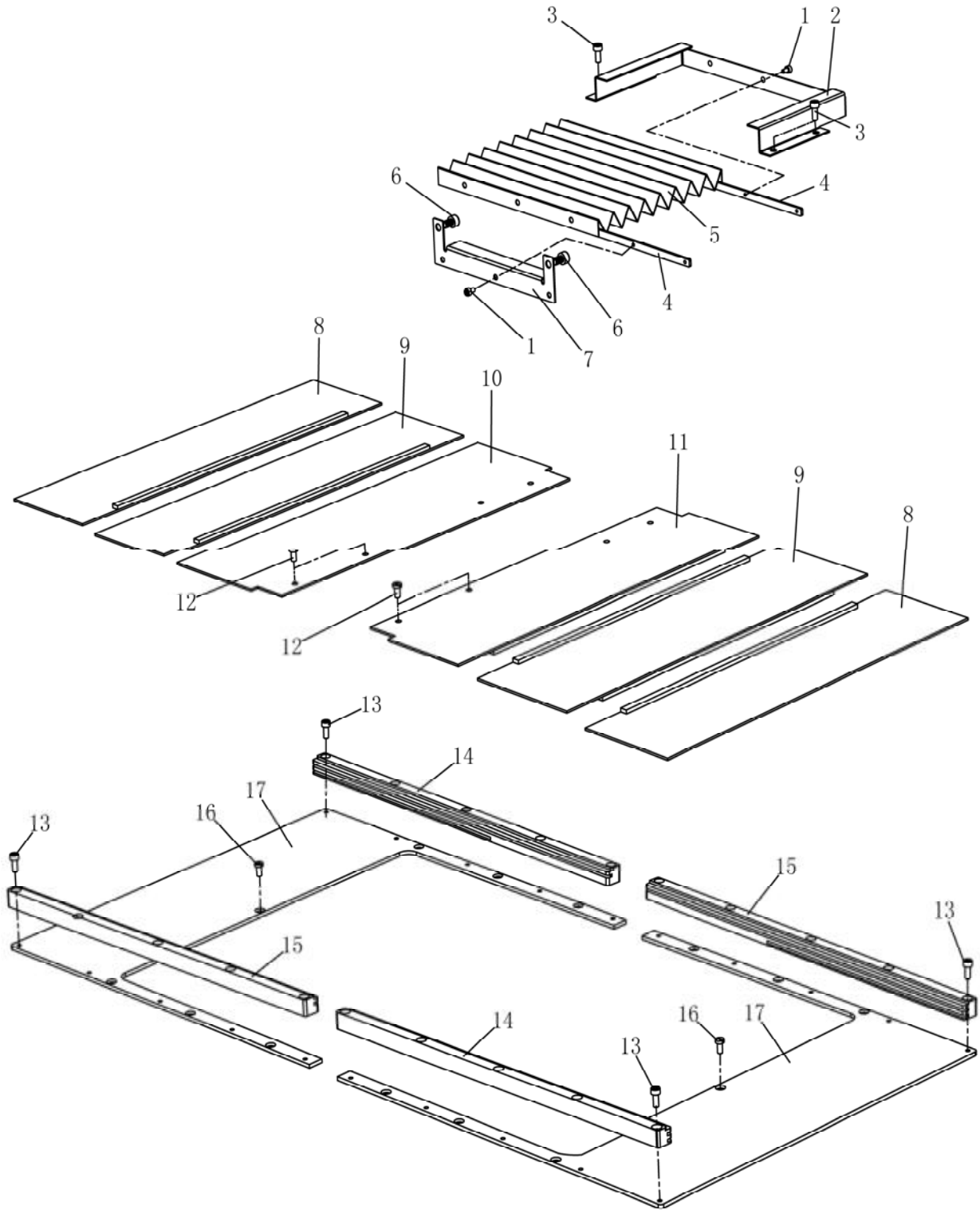

G. X-Y TABLE MECHANISM (三)

序号	样本编号	名 称	数量	备 注
G01	H415030050	Screw	6	M3×5
G02	HN75D78001	Shutter guide	1	
G03	H415040080	Screw	4	M4×8
G04	HN75D88001	Plate	2	
G05	HN75D58001	Shutter	1	
G06	H6684E8001	Screw	2	M5×8
G07	HN75D68001	Shutter setting plate	1	
G08	HN75D37101	Movable cover	2	
G09	HN75D27101	Movable cover	2	
G10	HN75D17101	Movable cover(L)	1	
G11	HN75D07101	Movable cover(R)	1	
G12	H6623C8001	Screw	4	M4×8
G13	H415040100	Screw	20	M4×10
G14	HN74D88001	Cover rail(R)	2	
G15	HN74D98001	Cover rail(L)	2	
G16	H6623C8001	Screw	14	M4×8
G17	HN74D78001	Fixation	2	

H. WORK HOLDER MECHANISM(AIR OPERATED)

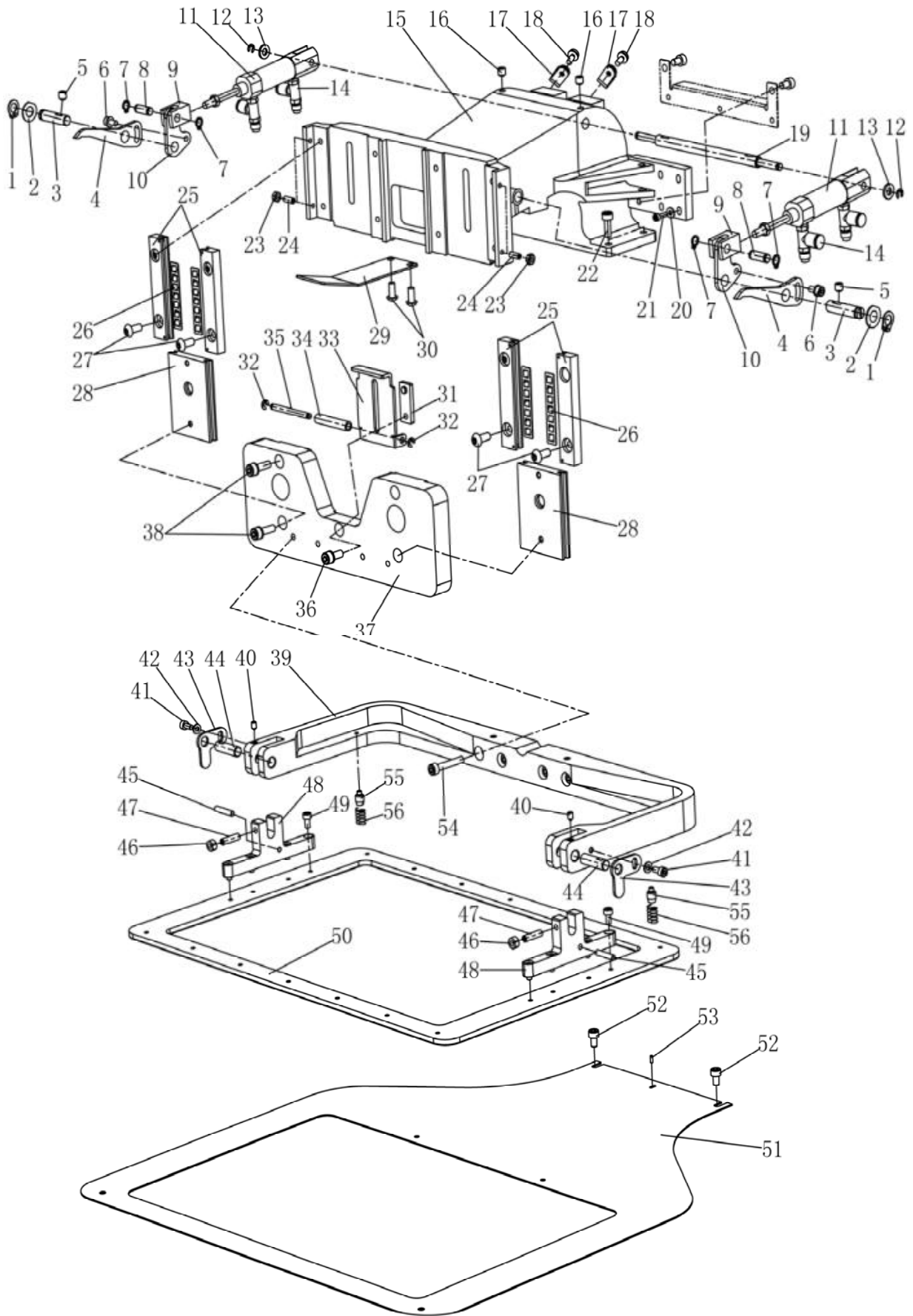

H. WORK HOLDER MECHANISM(AIR OPERATED)

序号	样本编号	名 称	数量	备 注
H01	H007013060	E-type retaining ring	2	
H02	H005001080	Washer	2	
H03	HN71E38001	Axle	2	
H04	HN71E18001	Pressure lever	2	
H05	H431060060	Screw	2	M6×6
H06	H6637E8001	Screw	2	M4×8
H07	H007013050	E-type retaining ring	4	
H08	HN71E88001	Pin	2	
H09	HN71E78001	Cylinder joint	2	
H10	HN71E28001	Connecting rod	2	
H11	HN71E57101	air cylinder	2	AirTAC:PB16×20CB
H12	H007013035	E-type retaining ring	2	
H13	H005001050	Washer	2	
H14	1240401801	Joint	4	ESL4-M5
H15	HN70E68001	Clamp bracket	1	
H16	H431060060	Screw	2	M6×6
H17	H6648I8001	Nylon clip	2	AB-6N
H18	H6682D8001	Screw	2	M4×10
H19	HN71E48001	Axle	1	
H20	H005001030	Washer	8	
H21	H415030120	Screw	8	M3×12
H22	H6676E8001	Screw	4	M5×14
H23	H003002040	Nut	4	M4
H24	H431040100	Screw	4	M4×10
H25	HN70E88001	Fixed race	4	
H26	HN71E08001	Roller retainer	4	
H27	H416050120	Screw	8	M5×12
H28	HN70E98001	Movable race	2	
H29	HN72E68001	Work clamp spring	1	
H30	H416050120	Screw	2	M5×12
H31	HN72E58001	Nut	1	
H32	H007013030	E-type retaining ring	2	
H33	HN72E18001	Work clamp stopper	1	
H34	HN72E28001	Rubber bush	1	
H35	HN72E38001	Pin	1	
H36	HA19041855	Screw	1	M5×16
H37	HN71E98001	Work clamp	1	
H38	HA19041855	Screw	4	M5×16
H39	HN72E98001	Press pole	1	
H40	H431040060	Screw	2	M4×6
H41	H415040080	Screw	2	M4×8
H42	H3200I2030	Washer	2	
H43	HBI3278081	Limit place plate	2	

H. WORK HOLDER MECHANISM(AIR OPERATED)

序号	样本编号	名 称	数量	备 注
H44	HBI3277081	Axle	2	
H45	HBI3275081	Pin	2	
H46	H003002050	Nut	2	M5
H47	H426050180	Screw	2	M5×18
H48	HBI3274081	Connect pedestal	2	
H49	H415040080	Screw	8	M4×8
H50	HN73E27101	Work clamp assy	1	
H51	HN73E18001	Feed plate	1	
H52	H6684E8001	Screw	4	M5×8
H53	H605020090	Pin	1	
H54	H415050300	Screw	4	M5×30
H55	HN73E88001	Screw	2	M4
H56	HK337D8001	Spring	2	

I. PRESSER FOOT MECHANISM(一)

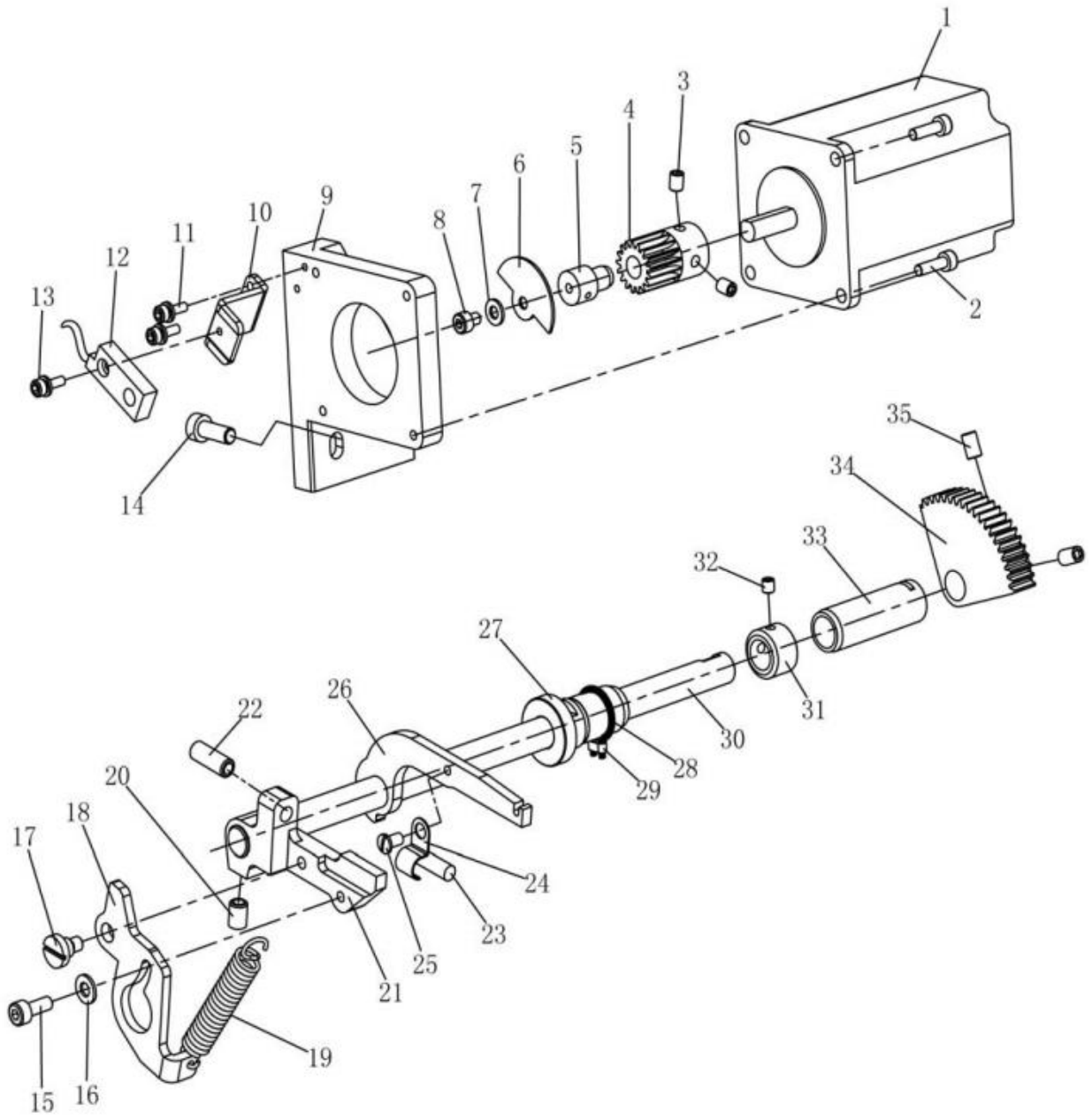

I. PRESSER FOOT MECHANISM(一)

序号	样本编号	名 称	数量	备 注
I01	HN70F98001	Stepping motor	1	
I02	H415040140	Screw	4	M4×14
I03	H431050060	Screw	2	M5×6
I04	HA17905-37	Gear	1	17
I05	HN71F08001	Detector plate spacer	1	
I06	HN71F58001	Detector plate	1	
I07	H6685D8001	Washer	1	
I08	H415040050	Screw	1	M4×5
I09	HN70F68001	Motor bracket	1	
I10	HN70F78001	Install plate	1	
I11	HZ11030100	Screw	2	M3×10
I12	HN71F17101	Detector	1	
I13	HZ11030100	Screw	1	M3×10
I14	H415060160	Screw	2	M6×16
I15	H6696F8001	Screw	1	M4×10
I16	H6685D8001	Washer	1	
I17	HM038E8001	Screw	1	11/64(40)×5
I18	HA17905-26	Frame	1	
I19	HA17905-29	Spring	1	
I20	H431060080	Screw	1	M6×8
I21	HA17905-25	Lifting lever	1	
I22	H431060160	Screw	1	M6×16
I23	HA17905-28	Felt	1	
I24	H3200K0190	Holder	1	
I25	HA106B7101	Screw	1	9/64(40)×6
I26	HA17905-27	Lifting lever	1	
I27	HA17901-41	Bushing	1	
I28	HA17901-40	Oil braid	1	
I29	H3200G2030	Knitting wool clamp	1	
I30	HN70F88001	Lifting shaft	1	
I31	HA715N0711	Collor	1	
I32	HA105D0662	Screw	1	SM1/4×40
I33	HN73B98001	Bushing	1	
I34	HA17905-32	Gear	1	58
I35	H431050080	Screw	2	M5×8

J. PRESSER FOOT MECHANISM(二)

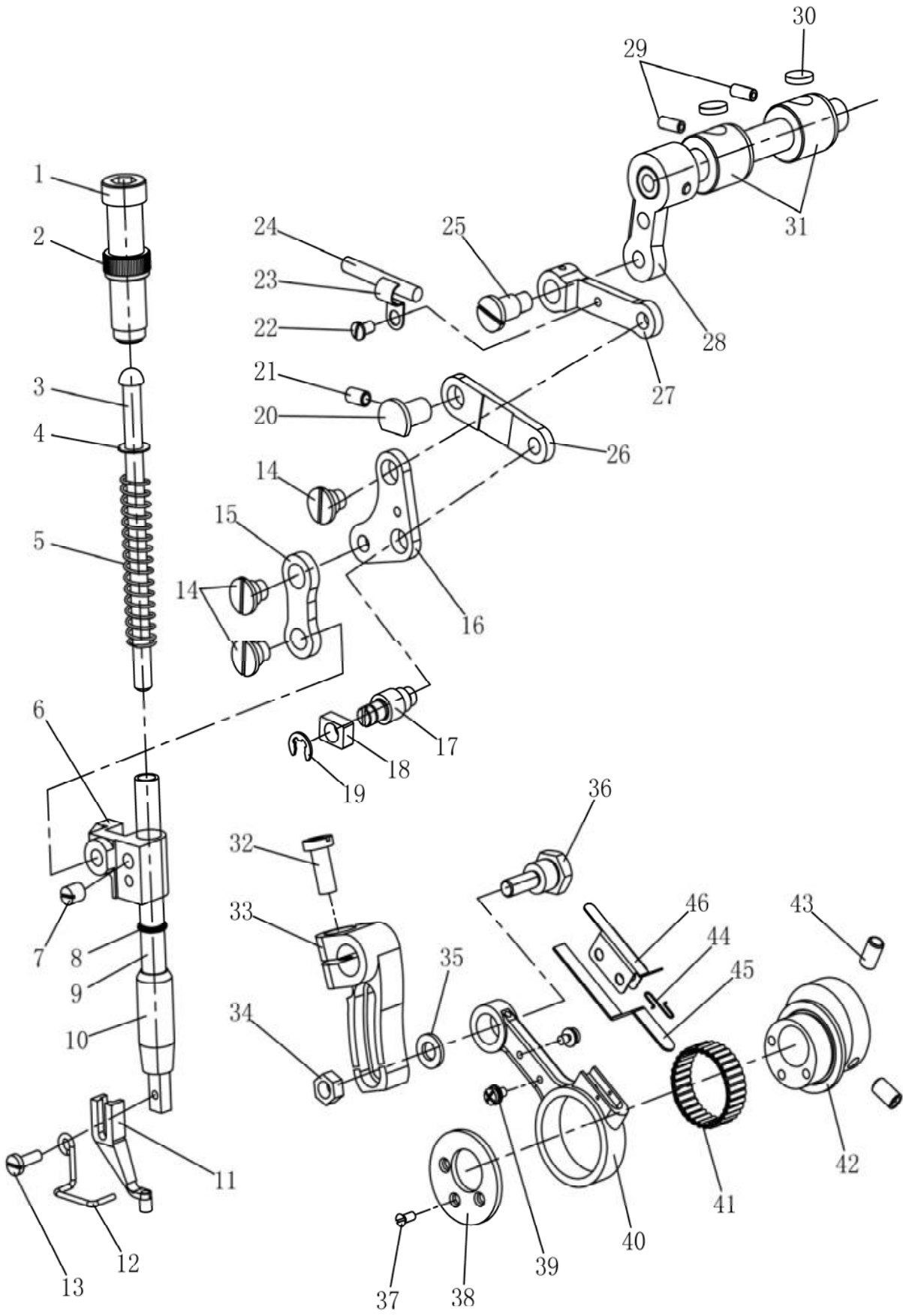

J. PRESSER FOOT MECHANISM(二)

序号	样本编号	名 称	数量	备 注
J01	HA309H0681	Screw	1	1/2(28)×49
J02	HA117H0692	Nut	1	1/2(28)
J03	HM025F8001	Presser bar guide	1	
J04	H662IB8001	Spacer	1	
J05	HM026F8001	Presser spring	1	
J06	H6027H8001	Presser bar holder	1	
J07	HA3411D308	Screw	1	15/64(28)×6
J08	70018	O ring	1	7×1.8-A
J09	HM029F8001	Presser bar	1	
J10	HA17901-11	Bushing	1	
J11	HM027F8001	Presser foot	1	
J12	HA17905-22	Needle guard	1	
J13	HA100H2150	Screw	1	9/64(40)×11
J14	HM016F8001	Screw	3	1/4(40)×4
J15	HM014F8001	Link	1	
J16	HM011F8001	Link	1	
J17	HA17905-18	Screw	1	1/4(40)×4
J18	HA100C2200	Square block	1	
J19	H007013050	E-type retaining ring	1	
J20	HA17905-21	Pin	1	
J21	H431050080	Screw	1	M5×8
J22	HA106B0676	Screw	1	9/64(40)×6
J23	H3200K0190	Holder	1	
J24	H2000M0080	Felt	1	
J25	HA17905-20	Screw	1	1/4(40)×7
J26	HM013F8001	Link	1	
J27	HA17905-17	Link	1	
J28	HA17905-14	Lifting lever assy	1	
J29	H431040100	Screw	2	M4×10
J30	H6616B8001	Felt	1	
J31	HA17901-13	Bushing	1	
J32	H2012N0652	Screw	1	1/4(24)×16
J33	H2100I2010	Link	1	
J34	GB 52008	Nut	1	M6×0.75
J35	H005001060	Washer	1	
J36	HA17905-12	Screw	1	M6×0.75
J37	HA7311C306	Screw	3	9/64(40)×7
J38	HA17905-05	Washer	1	
J39	H6698B8001	Screw	2	M3×6
J40	HA17905-08	Link	1	
J41	HA17905-04	Needle bearing	1	K25×29×10
J42	HA17905-03	Eccentric cam	1	
J43	HA710E0692	Screw	2	1/4(40)×10

J. PRESSER FOOT MECHANISM(二)

序号	样本编号	名 称	数量	备 注
J44	H20111C106	Holder	1	
J45	HA17905-10	Felt	1	H 2mm L 66mm
J46	HA17905-09	Felt holder	1	

K. THREAD TRIMMING MECHANISM

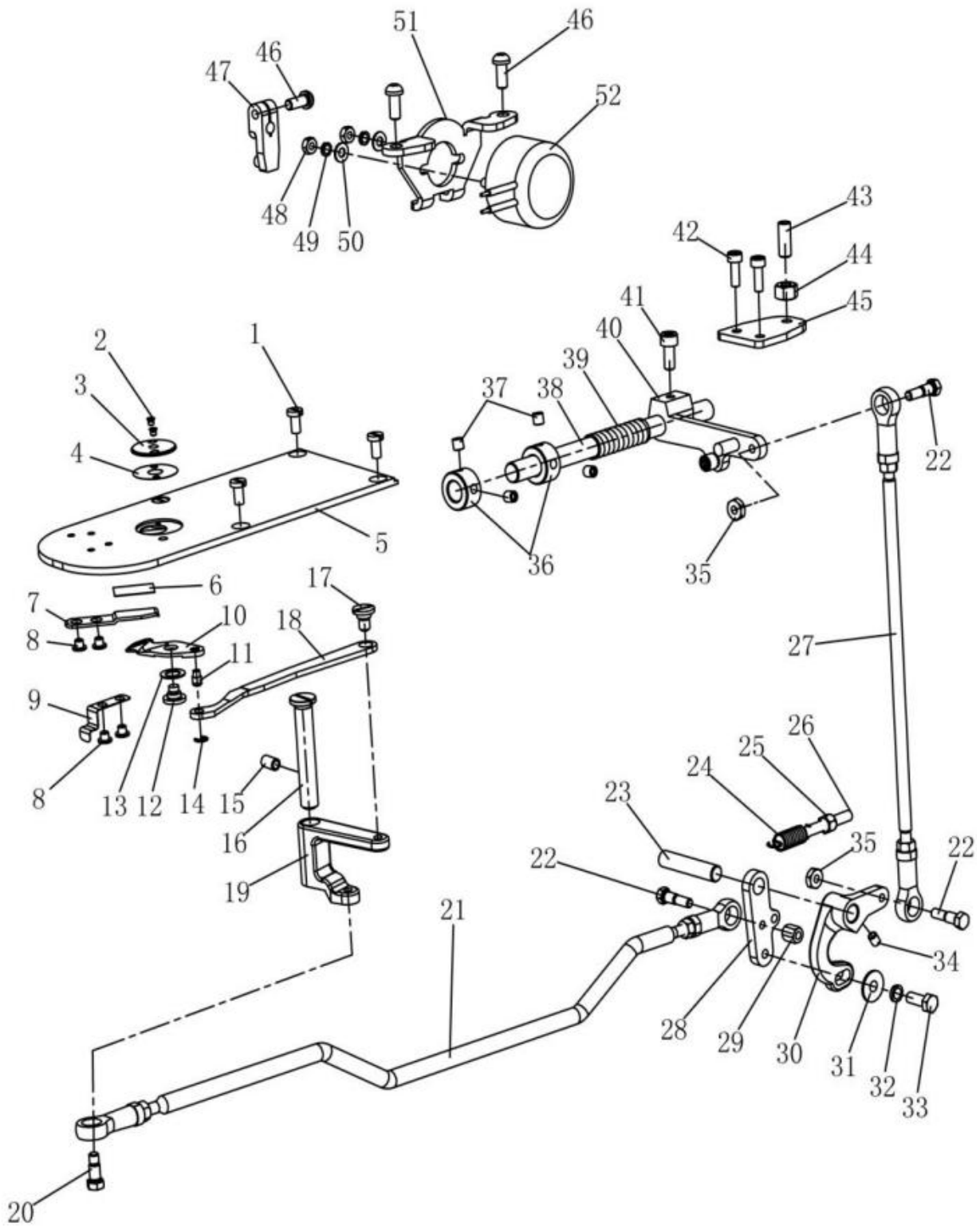

K. THREAD TRIMMING MECHANISM

序号	样本编号	名 称	数量	备 注
K01	H6623C8001	Screw	4	M4×8
K02	H6675F8001	Screw	2	3/32 (56) × 2.8
K03	H6676F8001	needle plate	1	
K04	H6677F8001	Spacer	1	
K05	H6681F8001	Slide plate	1	
K06	H6695F8001	Spacer	1	
K07	H6673F8001	Fixed knife	1	
K08	H6692B8001	Screw	4	9/64 (40) × 3.2
K09	H6680F8001	Spring	1	
K10	H6671F8001	Movable knife	1	
K11	H6672F8001	Pin	1	
K12	H6678F8001	Screw	1	9/64 (40) × 2.9
K13	H6679F8001	Wave washer	1	
K14	H007013025	E-type retaining ring	1	
K15	H431050080	Screw	1	M5×8
K16	H6664F8001	Shaft	1	
K17	H6666F8001	Screw	1	3/16 (28) × 6
K18	H6667F8001	Lever	1	
K19	H6658F8001	Crank	1	
K20	H6659F8001	Screw	1	11/64 (40) × 5
K21	HN70G77101	Connecting rod assy	1	
K22	H6644F8001	Bolt	3	11/64 (40)
K23	H6654F8001	Shaft	1	
K24	HA17906-16	Spring	1	
K25	H003024050	Nut	1	M5
K26	HN70G58001	Screw	1	
K27	H6631F7101	Link	1	
K28	H6653F8001	Crank	1	
K29	H6643F8001	Nut	1	11/64 (40)
K30	H6651F8001	Crank	1	
K31	HA300J2230	Washer	1	
K32	H005008050	Spring washer	1	
K33	H415050120	Screw	1	M5×12
K34	HA100B2110	Screw	1	11/64 (40) × 5.5
K35	H6641F8001	Nut	2	11/64 (40)
K36	H6625F8001	Collor	1	
K37	H431050050	Screw	2	M5×5
K38	HN70G48001	Cam shaft	1	
K39	H6623F8001	Spring	1	
K40	H6635F7101	Thread crank assy	1	
K41	H415050120	Screw	1	M5×12
K42	H669DE8001	Screw	2	M4×12
K43	H431060160	Screw	1	M6×16

K. THREAD TRIMMING MECHANISM

序号	样本编号	名 称	数量	备 注
K44	H003001060	Nut	1	M6
K45	HA17906-11	Holder plate	1	
K46	H416050120	Screw	3	M5×12
K47	H0G4068001	Crank	1	
K48	H6683D8001	Nut	2	M4
K49	H6613F8001	Spring washer	2	
K50	H6685D8001	Washer	2	
K51	HA17906-04	mounting plate	1	
K52	HN71G97101	Solenoid assy	1	

L. WIPER MECHANISM

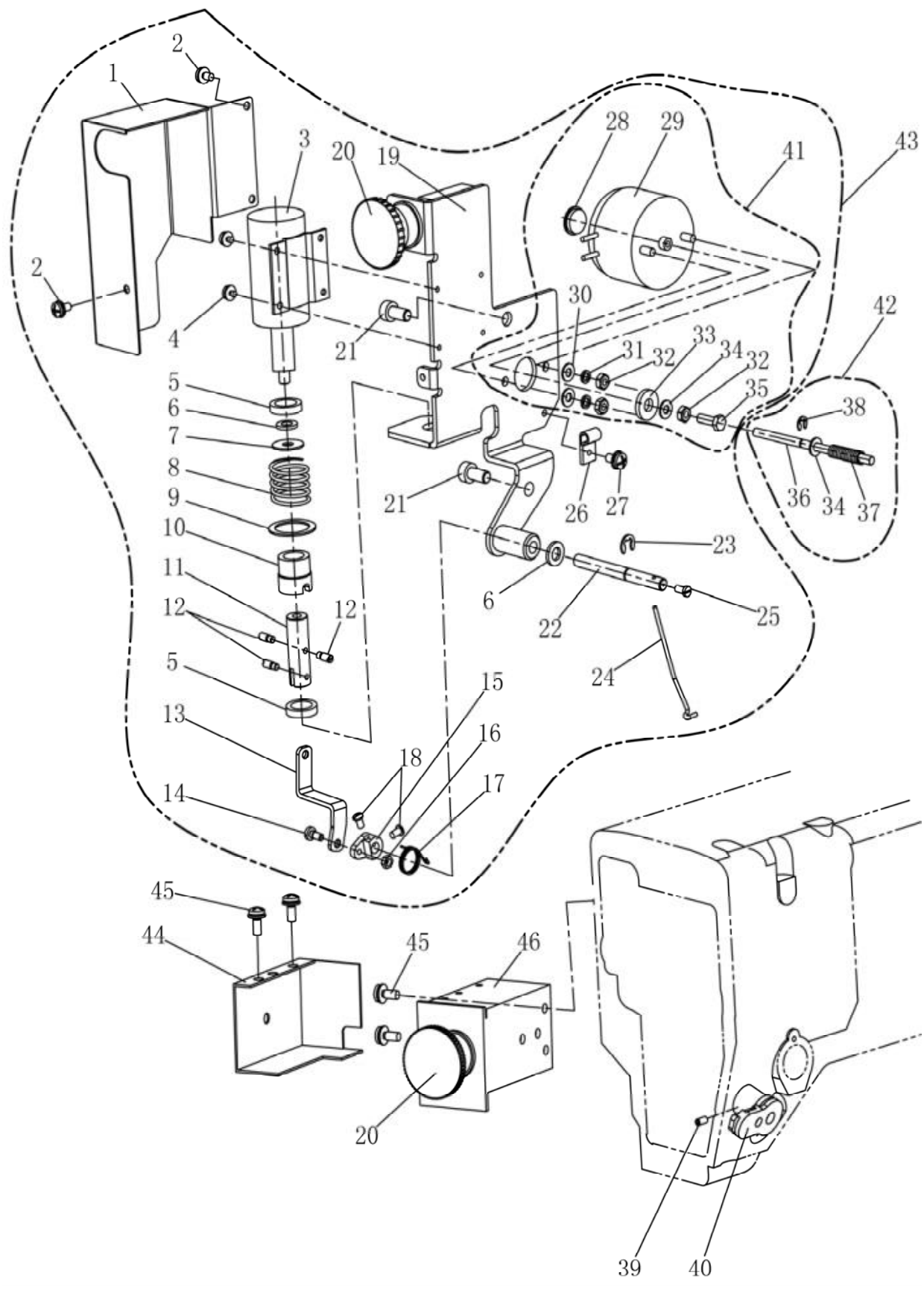

L. WIPER MECHANISM

序号	样本编号	名 称	数量	备 注
L01	HN71H38001	Cover	1	
L02	H6642B8001	Screw	3	M4×8
L03	HN70H97101	Solenoid assy	1	
L04	HA708P0669	Screw	4	M3×5
L05	HN72H28001	Rubber washer	2	Φ18/Φ12.5/4
L06	H005001060	Washer	2	
L07	HA17907-10	Spacer	1	
L08	HA17907-13	Spring	1	
L09	HA17907-11	Spacer	1	
L10	HN71H08001	Stopper	1	
L11	HA17907-07	Joint	1	
L12	HA700P0030	Screw	3	
L13	HA17907-08	Link	1	
L14	HA710P0674	Screw	1	9/64(40)×9
L15	HA17907-19	Link	1	
L16	HA710P0673	Nut	1	9/64(40)
L17	HA17907-24	Spring	1	
L18	HA106B0676	Screw	2	9/64(40)×6
L19	HN71H17101	Wiper setting plate	1	
L20	HN72H17101	Stop switch assy	1	
L21	H415060120	Screw	2	M6×12
L22	HA17907-18	Shaft	1	
L23	H007013050	E-type retaining ring	1	
L24	HA17907-25	Wiper	1	
L25	HA104G0654	Screw	1	1/8(44)×6
L26	H6648I8001	Nylon clip	1	AB-6N
L27	H6642B8001	Screw	1	M4×8
L28	H2000B2010	Rubber plug	1	
L29	HK40H98001	Solenoid assy	1	
L30	H005004040	Washer	2	
L31	H005008040	Spring washer	2	
L32	H003002040	Nut	3	M4
L33	HK41H18001	Washer	1	Φ15×2.5
L34	H005001040	Washer	2	
L35	H103040120	Bolt	1	M4×12
L36	HA17907-39	Pin	1	
L37	HA17907-40	Spring	1	
L38	H007013030	E-type retaining ring	1	
L39	HN70H57101	Solenoid assy	1	
L40	H431030060	Screw	1	M3×6
L41	HK40H87101	Solenoid assy	1	peculiar order
L42	HN72H57101	Pin	1	peculiar order
L43	HN70H47101	Wiper assy	1	peculiar order

L. WIPER MECHANISM

序号	样本编号	名 称	数量	备 注
L44	HK40H68001	Cover	1	M4×10
L45	H6682D8001	Screw	4	
L46	HK40H78001	setting plate	1	

M. OIL LUBRICATION MECHANISM

I

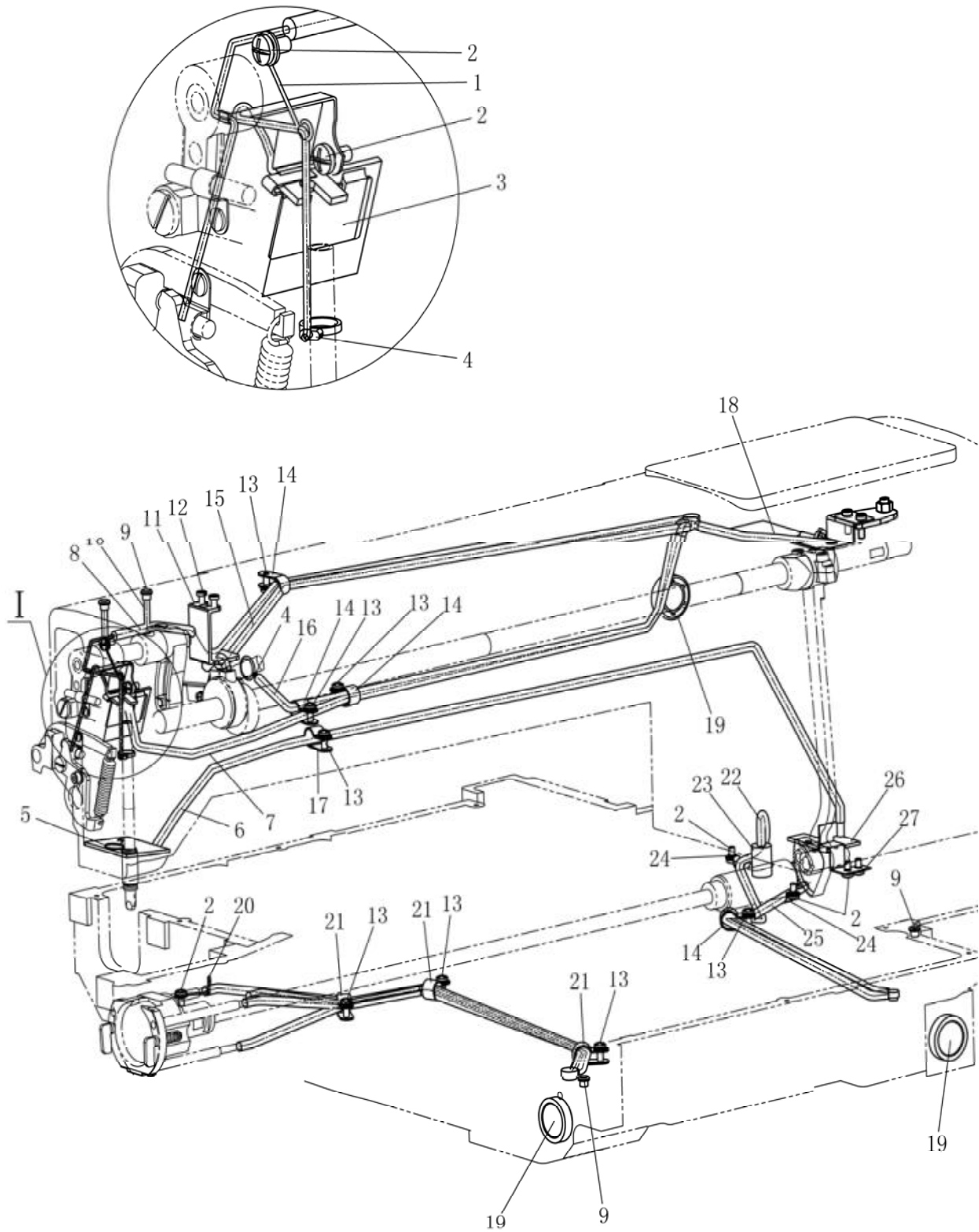

M. OIL LUBRICATION MECHANISM

序号	样本编号	名 称	数量	备 注
M01	HM008I8001	Felt holder	1	
M02	H6642B8001	Screw	9	M4×8
M03	HA17908-06	Felt holder	1	
M04	H3200G2030	Felt holder	2	
M05	HA300I2060	Holder	1	
M06	HN71I87101	Felt	1	
M07	HN70I67101	Oil pipe assy	1	
M08	HN70I97101	Oil pipe assy	1	
M09	HA300B2110	Rubber plug	4	
M10	HA17908-38	Felt	2	
M11	HN70I58001	Cover	1	
M12	H6623C8001	Screw	2	M4×8
M13	H6682D8001	Screw	10	M4×10
M14	H6729N8001	Nylon clip	4	AB-5N
M15	HN71I27101	Oil pipe assy	1	
M16	HN71I57101	Oil pipe assy	1	
M17	H6645H8001	Nylon clip	1	AB-4N
M18	HA17908-21	Oil pipe assy	1	
M19	H6614H8001	Oil gauge	3	
M20	H6612H8001	Holder	1	
M21	H6648I8001	Nylon clip	3	AB-6N
M22	HN72I27101	Oil pipe assy	1	
M23	H6608H8001	Felt	1	
M24	H32311D606	Holder	2	
M25	HN72I57101	Oil pipe assy	1	
M26	H6606H8001	Felt	1	
M27	H6605H8001	Holder	1	

N. CABLE COMPONENT & DETECTOR MECHANISM

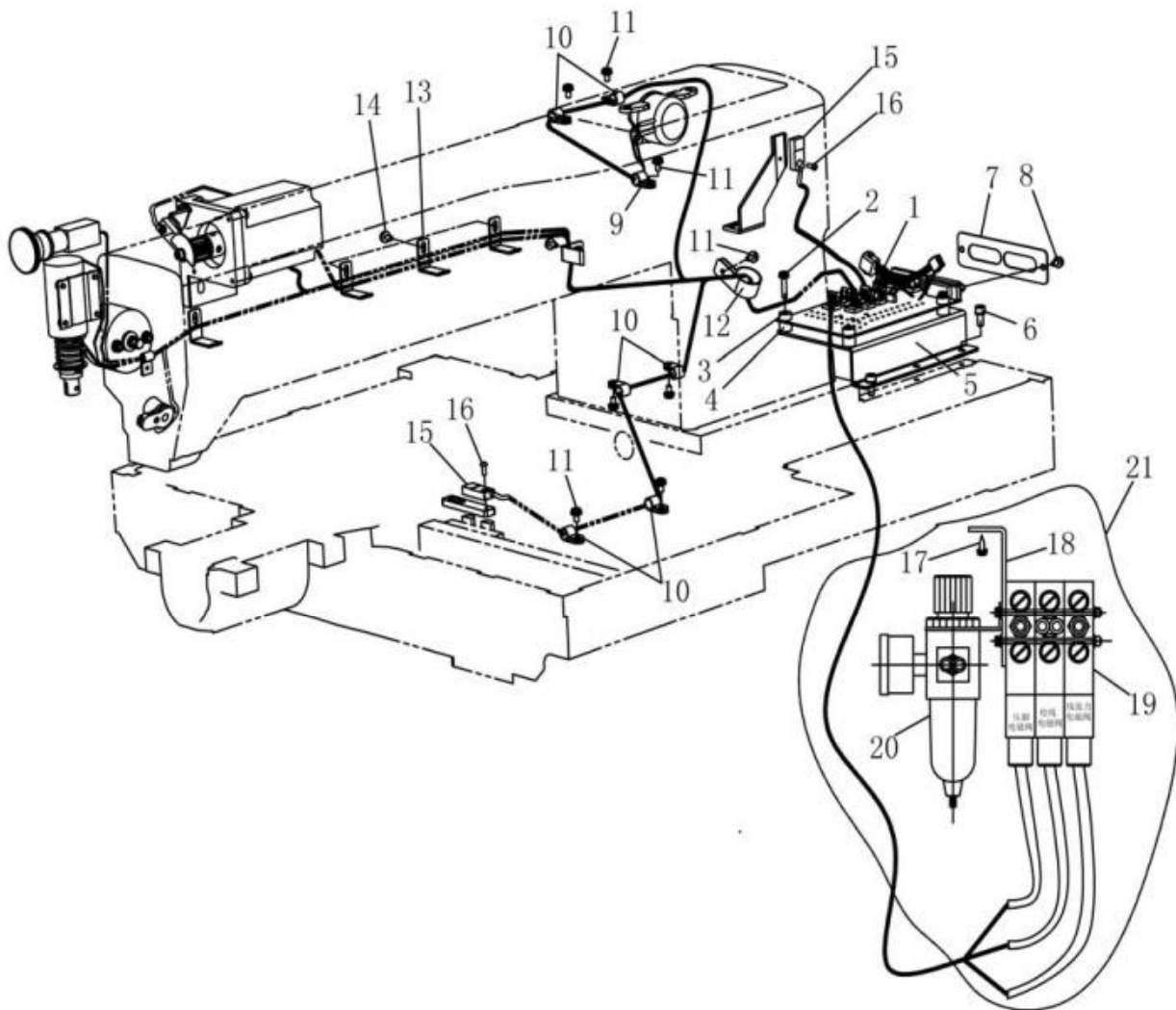

N. CABLE COMPONENT & DETECTOR MECHANISM

序号	样本编号	名 称	数量	备 注
N01	HN70J78001	Print circuit board	1	
N02	H6609I8001	Screw	4	M4×20
N03	H6607I8001	Nylon bush	4	
N04	H6608I8001	Nylon bush	4	
N05	HN70J88001	Bracket	1	
N06	H6692D8001	Screw	3	M5×12
N07	HN70J98001	Connector panel	1	
N08	H6697F8001	Screw	8	M4×8
N09	H6645H8001	Nylon clip	1	AB-4N
N10	H6679D8001	Nylon clip	7	AB-3N
N11	H6642B8001	Screw	9	M4×8
N12	HD44JM8001	Nylon clip	1	
N13	HA17909-15	Code holder	6	
N14	H6697F8001	Screw	5	M4×8
N15	HN71F28001	Detector	2	
N16	H401030080	Screw	2	M3×8
N17	H802035190	Screw	3	3.5×19
N18	H4923N8001	Setting plate valve	1	
N19	H4918N8001	Valve	3	4V210-08-DC24V
N20	H4915N8001	Filter regulator	1	(AIRTAC)
N21	GJD-7-3D	GJD-1	1	

O. ACCESSORIES (一)

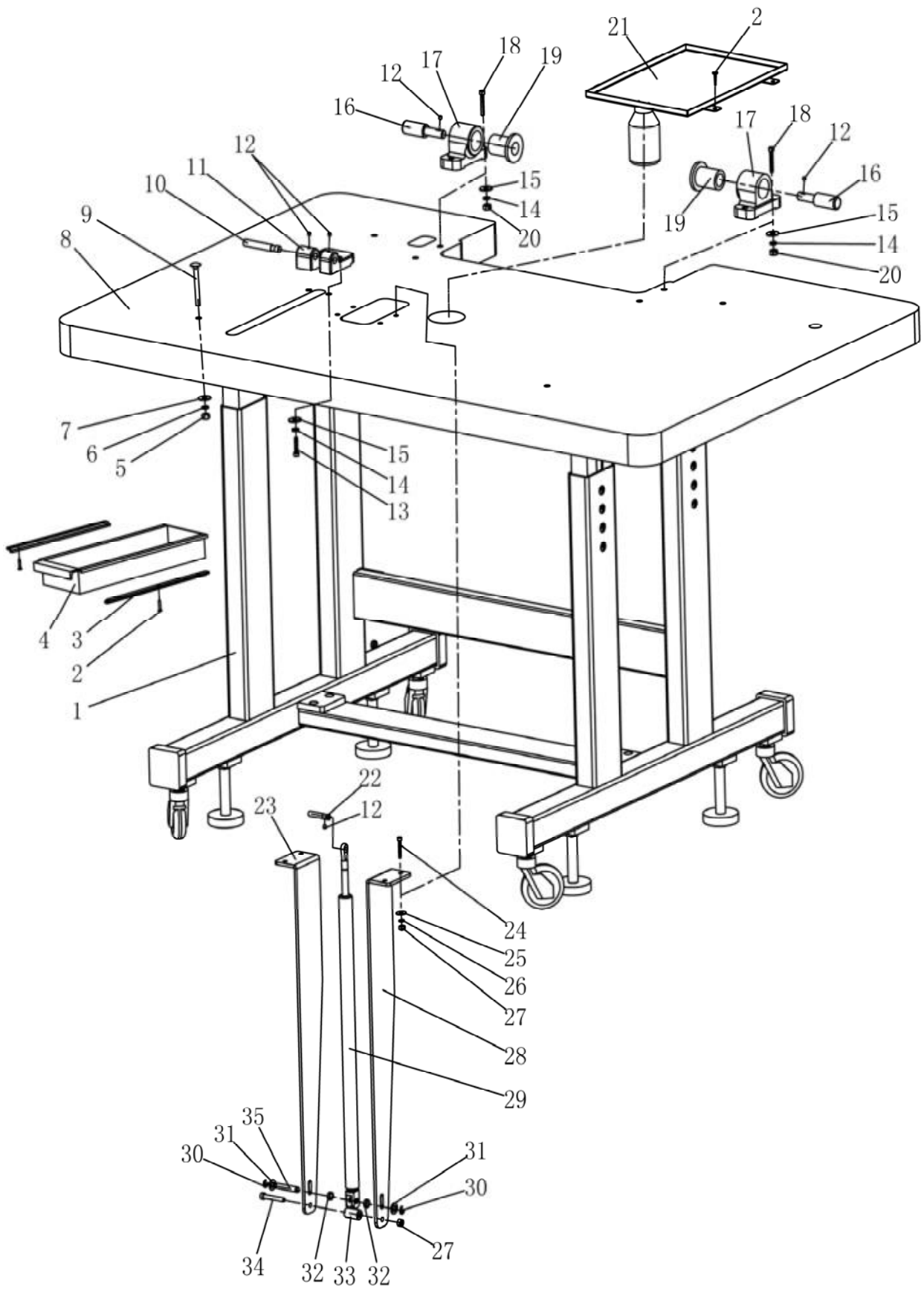

O. ACCESSORIES (一)

序号	样本编号	名 称	数量	备 注
001	HN72K47101	Leg assy	1	
002	H802035190	Screw	10	3.5×19
003	HN73K38001	Rail	2	
004	HN73K28001	Drawer	1	
005	H003001080	Nut	4	M8
006	H005008080	Spring washer	4	
007	GB/T 96.1 8	Washer	4	
008	HN72K18001	Table top	1	
009	H125080700	Bolt	4	M8×75
010	HN71K08001	Support lever shaet	1	
011	HN71K18001	Support lever base	1	
012	H431060060	Screw	5	M6×6
013	H415080600	Screw	2	M8×60
014	H005008080	Spring washer	6	
015	H005007080	washer	6	
016	HN70K68001	Hinge shaft	2	
017	HN70K98001	Hinge holder	2	
018	H415080800	Screw	4	M8×80
019	HN70K88001	Rubber bush	2	
020	H003002080	Nut	4	M8
021	HN72K37101	Oil pan assy	1	
022	HN71K58001	Shaft	1	
023	HN71K28001	Holder absorber L	1	
024	H415060800	Screw	4	M6×80
025	H005007060	washer	4	
026	H005008060	Spring washer	4	
027	H003001060	Nut	5	M6
028	HN71K38001	Holder absorber R	1	
029	HN71K88001	Shock absorber gas	1	min:550 max:850
030	H007013060	E-type retaining ring	2	
031	H005001080	Washer	2	
032	HN71K78001	washer	2	
033	HN71K48001	Ball bushing	1	
034	H415060400	Screw	1	M6×40
035	HN71K68001	Shaft	1	

P. ACCESSORIES (二)

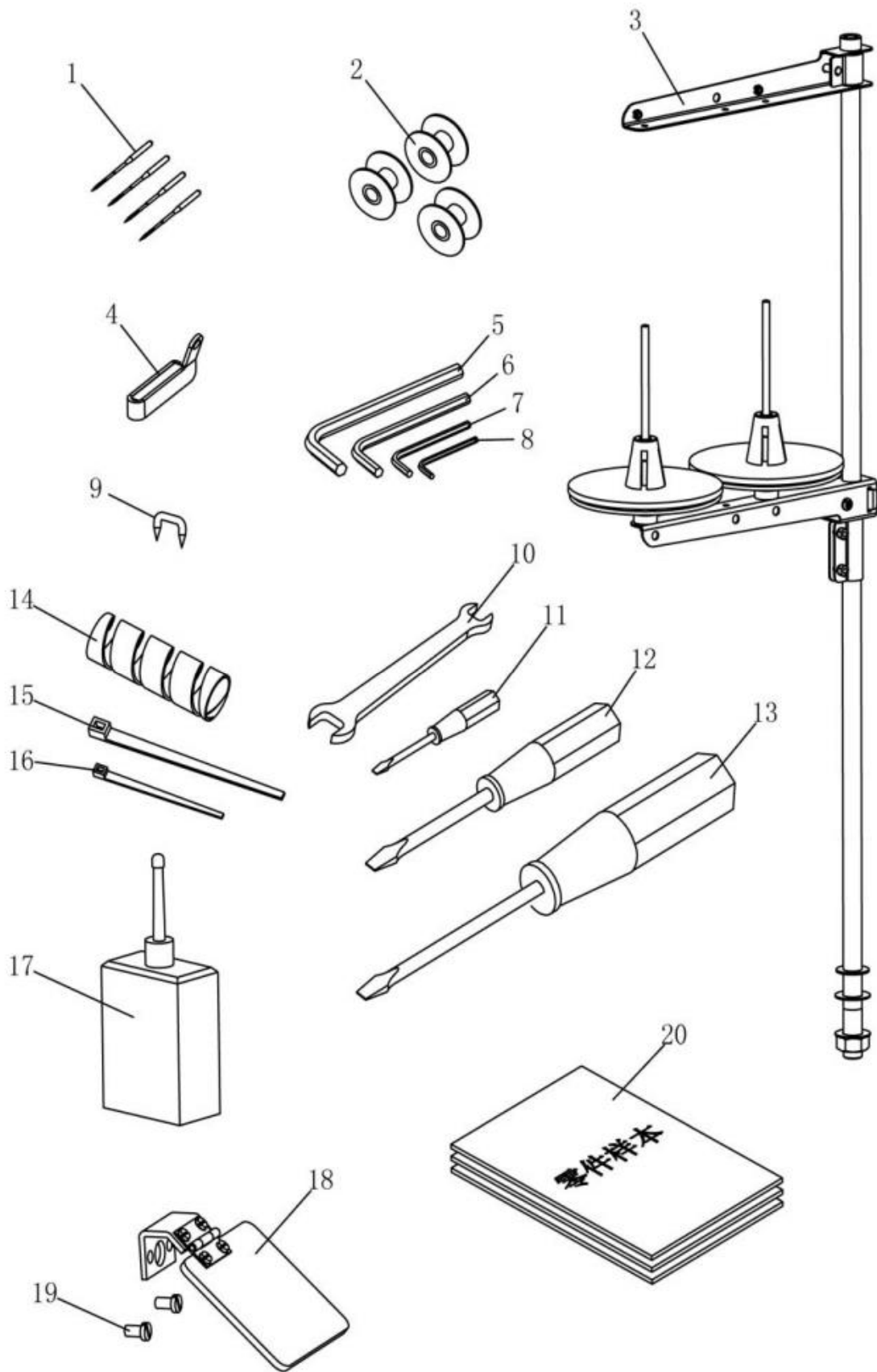

P. 附件（二）

序号	样本编号	名 称	数量	备 注
P01	JZDP1700G1801	Needle	4	
P02	H6685C8001	Bobbin	3	
P03	HA200J2030	Cotton stand assy	1	
P04	HM007K7101	Thread guide	1	peculiar order
P05	HB00001060	Hexagonal wrench 6	1	
P06	HB00001050	Hexagonal wrench 5	1	
P07	HB00001040	Hexagonal wrench 4	1	
P08	HB00001030	Hexagonal wrench 3	1	
P09	H6618J8001	Staple	4	
P10	HA300J2220	Spanner 10-14	1	10-14#
P11	HA300J2210	Screw driver(small)	1	
P12	HA300J2200	Screw driver(middle)	1	
P13	HA300J2070	Screw driver(large)	1	
P14	HD42IM8001	Coil belt	1	L=1m
P15	H6622J8001	Cord tie	2	
P16	HA300I2040	Cord tie	2	
P17	H200400069	Oiler	1	
P18	HA17910-58	Eye guard	1	
P19	H6642B8001	Screw	2	M4×8
P20	HN74K68001	Bart sample	1	

SHANGHAI BIAOZHUN HAILING SEWING MACHINERY CO., LTD.

ADD: NO.850 Shulin Road, Songjiang District Shanghai, P.R.China

Zip Code: 201612

Overseas Business: TEL: 86-21-64853303 FAX: 86-21-64854304

E-mail:sales@highlead.com.cn <http://www.highlead.com.cn>

The description covered in this manual is subject to change for improvement of the commodity without notice

2018.5. Printed