

HIGHLEAD

GC24698-BRHL/BLHL

**Long Arm Super Post Bed Compound Feed
Lockstitch Sewing Machine**

**Instruction Manual
Parts Catalog**

SHANGHAI BIAOZHUN HAILING SEWING MACHINERY CO.,LTD.

—CONTENTS—

OPERATION INSTRUCTION

1. PRECAUTIONS BEFORE STARTING OPERATION	1
2. SPECIFICATIONS	1
3. LUBRICATION	1
4. PRECAUTIONS OPERATION	2
5. INSTALLING NEEDLE	2
6. WINDING BOBBIN THREAD	2
7. THREADING	3
8. ADJUSTMENT OF STITCH LENGTH AND REVERSE SEWING	3
9. SETTING BOBBIN	3
10. ADJUSTMENT OF THREAD TENSION	4
11. ADJUSTMENT OF THE PRESSURE OF PRESSER FEET	4
12. TIMING BETWEEN THE HOOK AND NEEDLE	4
13. ADJUSTMENT OF THE HEIGHT OF THE FEED DOG	4
14. ADJUSTMENT OF THE VERTICAL STROKE WALK FOOT AND VIBRATING FOOT	5
15. TIMING BETWEEN THE NEEDLE AND HOOK	5
16. SAFETY CLUTCH DEVICE	6

PARTS CATALOG

A. ARM BED MECHANISM	7
B. THREAD TENSION REGULATOR MECHANISM	9
C. ARM SHAFT&MIDDLE SHAFT MECHANISM	11
D. PRESSER FOOT MECHANISM	14
E. NEEDLE BAR THREAD TAKE-UP MECHANISM	17
F. STITCH REGULATOR MECHANISM	20
G. LOWER SHAFT&FEEDING SHAFT MECHANISM	22
H. HOOK SADDLE MECHANISM	25
I. OIL LUBRICATION MECHANISM	27
J. ACCESSORIES	29
K. TOUCH BACK AND FOOT LIFT MECHANIS	31

1. PRECAUTIONS BEFORE STARTING OPERATION

1) Safety precautions:

(1) When turning the power on, keep your hands and fingers away from the area around/under the needle and the area around the pulley.

(2) Power must be turned off when the machine is not in use, or when the operator leaves the seat.

(3) Power must be turned off when tilting the machine head, installing or removing the “V” belt, adjusting the machine, or when replacing.

(4) Avoid placing fingers, hairs, bars etc., near the pulley, “V” belt, bobbin winder pulley, or motor when the machine is in operation.

(5) Do not insert fingers into the thread take-up cover, under/around the needle, or pulley when the machine is in operation.

(6) If a belt cover, finger guard, eye guard are installed, do not operate the machine without these safety devices.

2) Precautions before starting operation:

(1) If the machine’s oil pan has an oil sump, never operate the machine before filling it.

(2) If the machine is lubricated by a drop oiler, never operate the machine before lubricating.

(3) When a new sewing machine is first turned on, verify the rotational direction of the pulley with the power on. (The pulley should rotate counterclockwise when viewed from the pulley)

(4) Verify the voltage and (single or three) phase with those given on the machine nameplate.

3) Precautions for operating conditions:

(1) Avoid using the machine at abnormally high temperatures (35°C or higher) or low temperatures (5°C or lower) .

(2) Avoid using the machine in dusty conditions.

2. SPECIFICATIONS

Model	GC24698-BRHL/BLHL
Max.sewing speed	800r.p.m
Stitch length	10mm
Presser-foot stroke	8mm By hand 16mm By pneumatic
Needle size	DP×17 17# -23#
Lubrication system	Manual lubrication
Highness of post-bed	670mm
Motor	550W Sevor motor

3. LUBRICATION(Fig.1, Fig.2, Fig.3, Fig.4)

When a new sewing machine is used for the first time, or sewing machine left out of use for considerably long time is used again, replenish a suitable amount of oil to the portions indicated by arrow in the below figure.

Filling the oil to the fount timely.

Note:Filling the oil to the hook saddle everyday during operation.

See dripping of oil through the oil window to check oiling condition during operation.

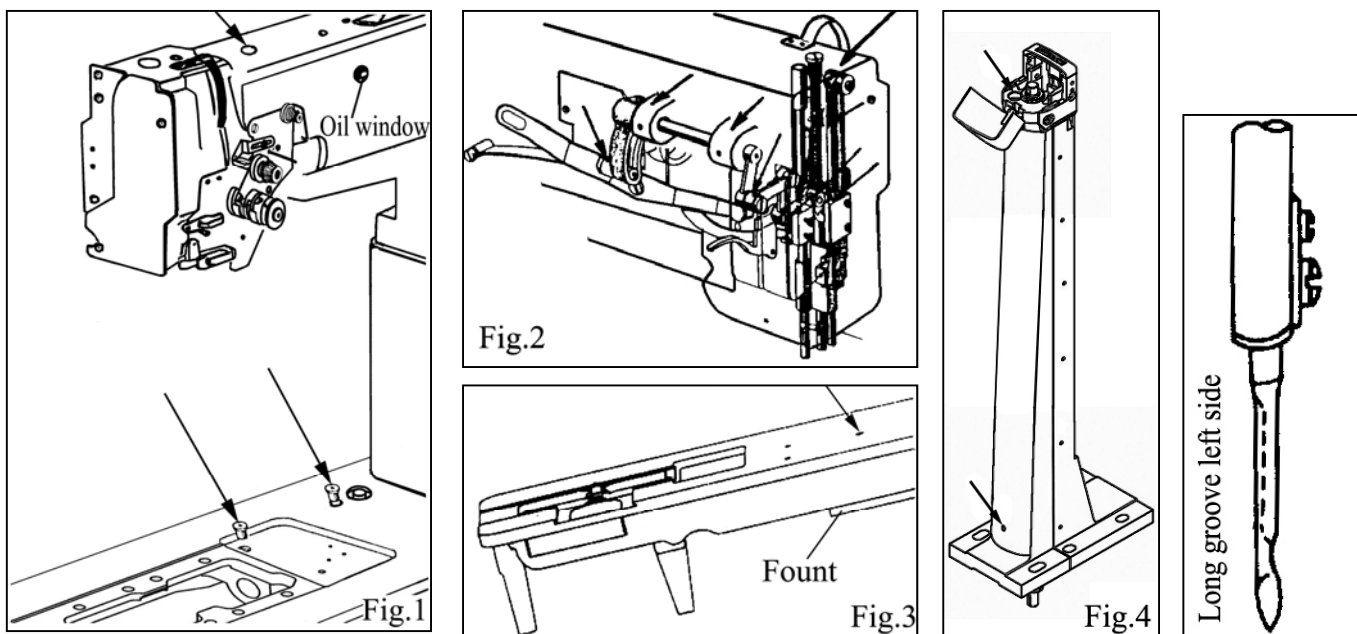

4. PRECAUTIONS OPERATION

- (1) When the power is turned on or off, keep foot away from the pedal.
- (2) It should be noted that the brake may not work when the power is interrupted or power failure occurs during sewing machine operation.
- (3) Since dust in the control box might cause malfunction or control troubles, be sure to keep the control box cover close during operation.

5. INSTALLING NEEDLE

Note: Before installing the needle, be sure to turn off the power.

To install the needle, turn the machine pulley over toward operator(or counter-clockwise) until the needle bar moves up to its highest point, put the needle up into the needle bar as deeply as it will go, with the long groove of the needle faced left side.Tighten the needle set screw securely.

6. WINDING BOBBIN THREAD(Fig.5)

Note:When bobbin thread is wound, keep the presser foot lifted

Thread tension: Particularly in the case of nylon or polyester thread,wind the bobbin loosely.

- (1) Press the bobbin onto the thread winding shaft.
- (2) Pass the thread for winding thread as shown in the figure, and wind the end of the thread clockwise around the bobbin several times, then wind the thread on the thread adjuster side counter-clockwise several times.

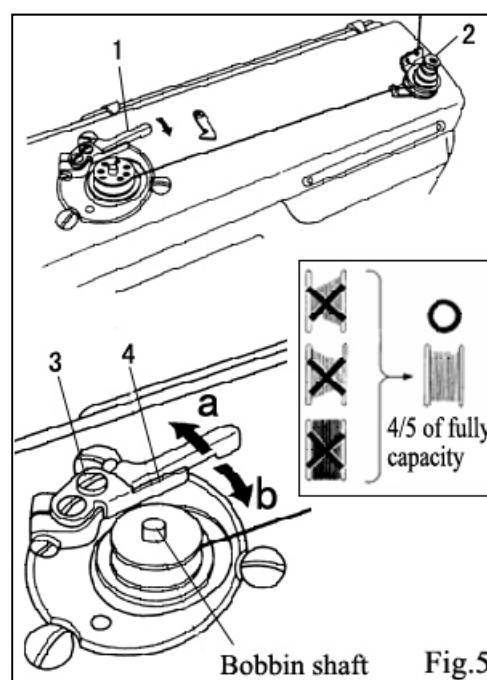

- (3) Press lever 1 in the direction of the arrow, and start the sewing machine.
- (4) The operation will automatically stop when winding is completed.
- (5) Adjustment of thread winding strength, adjust with the thread adjuster nut 2.
- (6) Adjustment of thread winding amount, adjust by loosening screw 3 and moving adjustment plate 4:

The thread winding amount will increase when moved in the direction of a.

The thread winding amount will decrease when moved in the direction of b.

7. THREADING(Fig.6, Fig.7)

- (1) Pass each needle thread through thread guide A.

Note:When thin slippery thread(polyster thread) is used pass the thread through thread guide B as show in Fig.6.

- (2) Thread take-up lever to the highest position,pass each thread in the order in Fig.7.

Note:Pressing the tension releasing button ,the thread can be pulled out easily.

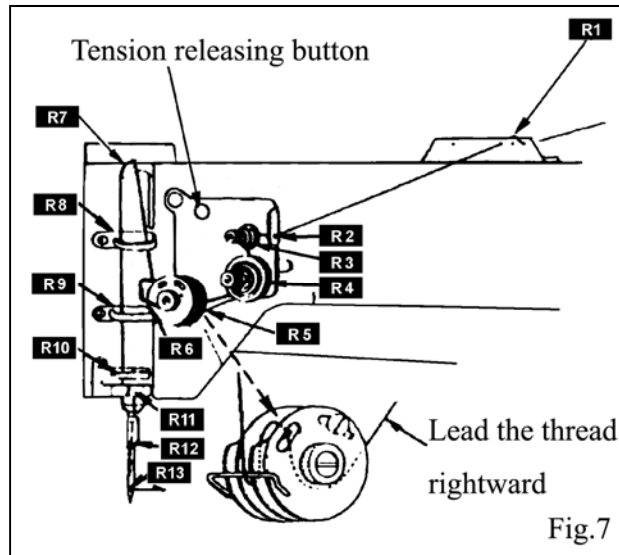
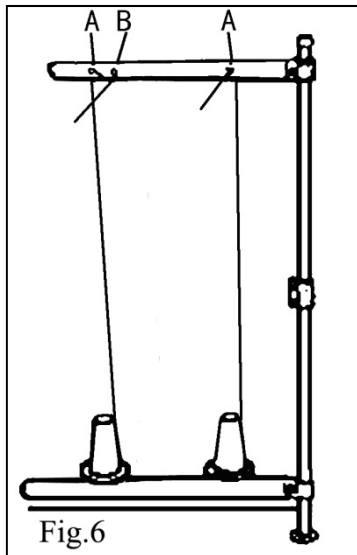

8. ADJUSTMENT OF STITCH LENGTH AND REVERSE SEWING(Fig.8)

Rotate the stitch length dial to change the stitch length.

When press the feed reversing lever or press the touch-back, reverse sewing will take place.Loose the lever or touch-back, reverse sewing will disappear.

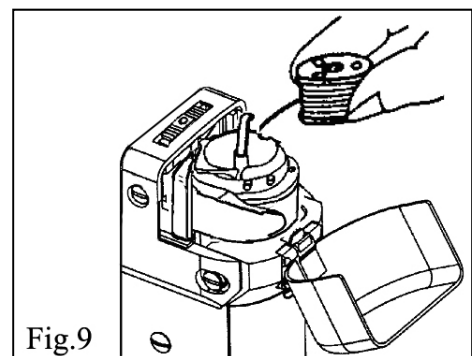
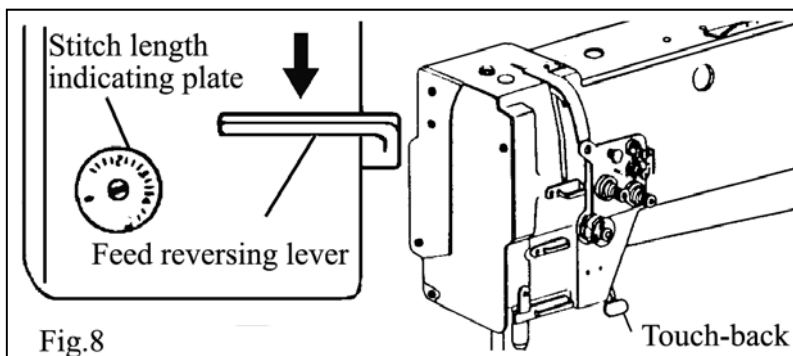

9. SETTING BOBBIN(Fig.9, Fig10)

Pull out the thread from the bobbin,then hold the bobbin into the bobbin shaft and push down the hinge latch.

Hold the needle thread by hand,turn the pulley a circle by right hand.By pulling up the needle thread,the bobbin thread will be lifted.Combination of bobbin thread and needle thread should be aligned and led back ward.

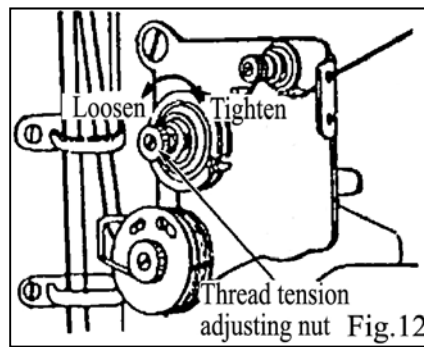
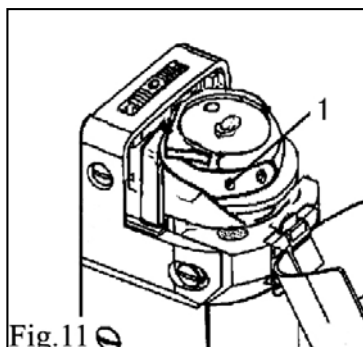
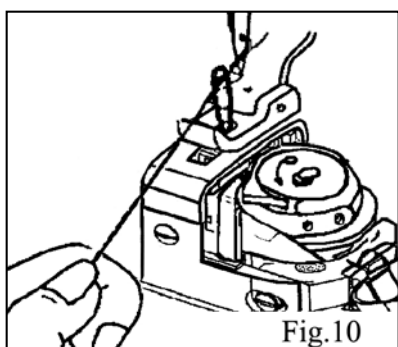

10. ADJUSTMENT OF THREAD TENSION(Fig.11, Fig.12, Fig.13)

There is virtually no need to adjust the bobbin thread tension, except for special kind of the thread, when slight adjustment will be necessary.

Turning the screw 1 clockwise will increase the tension of lower thread, otherwise, the tension of lower thread will decrease (Fig.12).

Needle thread tension should be adjusted in reference to bobbin thread tension.The needle thread tension can be adjusted by thread tension adjusting nut.

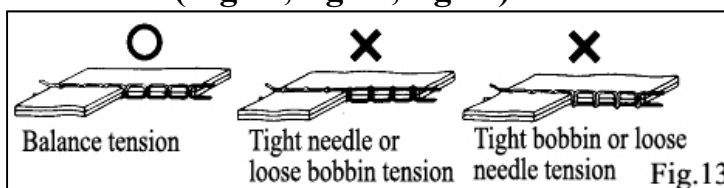

11. ADJUSTMENT OF THE PRESSURE OF PRESSER FEET(Fig.14)

The pressure of the presser feet is regulated by the adjusting screw.

To increase the pressure, turn the screw to clockwise, and decrease it, turn the screw to counter-clockwise.

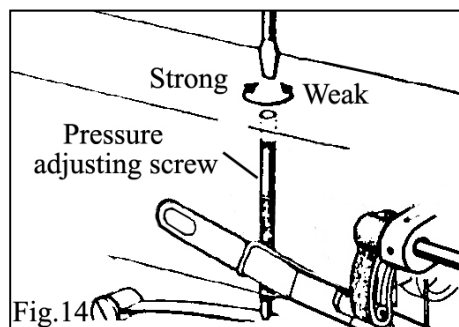

12. TIMING BETWEEN THE HOOK AND NEEDLE(Fig.15)

(1) Set the stitch length to "6" on the feed setting dial.

(2) When the needle is lifted 2.4mm from the lower dead point,the following positional relationship should be maintained:

a.The lower edge of needle eye should be 2.3mm below the hook point.

b.The center of the needle the hook point is on a line.

c.Gap between the hook point and the side face of needle should be 0.05mm.

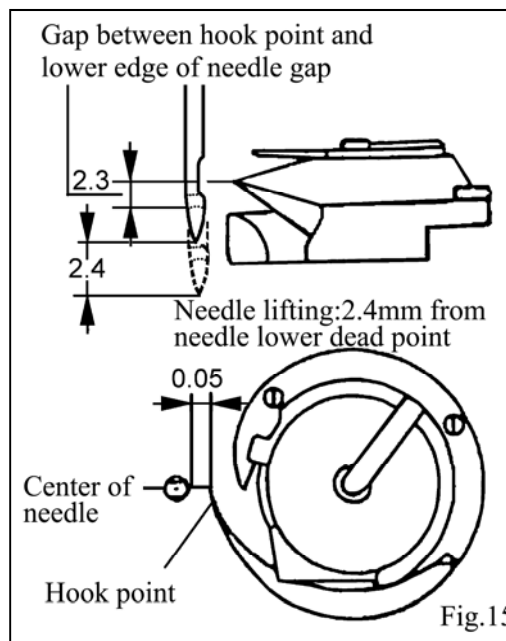

13. ADJUSTMENT OF THE HEIGHT OF THE FEED DOG(Fig.16)

The height of the feed dog should be adjusted for different materials:

(1) If the feed dog is too high,or the pressure of presser foot is too large,the materials will be damaged.

(2) If the feed dog is too low, or the pressure of presser foot is too small, the stitch length can't be assured.

(3) Feed dog height should be measured at the point where the needle is at the top position.

Thin material: The height of the feed dog is 0.8mm.

Usual material: The height of the feed dog is 1mm.

Heavy material: The height of the feed dog is 1.2mm.

Adjustment procedure:

- (1) Lean the machine head backward.
- (2) Turn the pulley by hand and stop when the feed dog rises to the maximum height.
- (3) Loose the feed bar forked connection set screw and adjust the height of the feed dog.
- (4) After adjusted, tightened the set screw.

Note: The feed dog height is factory-adjusted to 1.2mm.

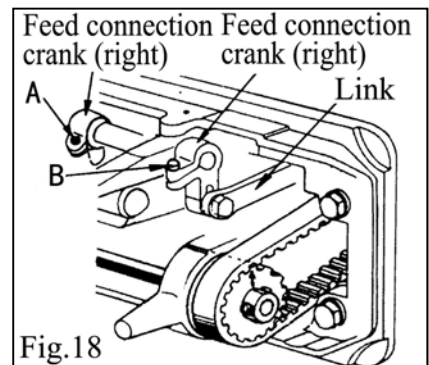
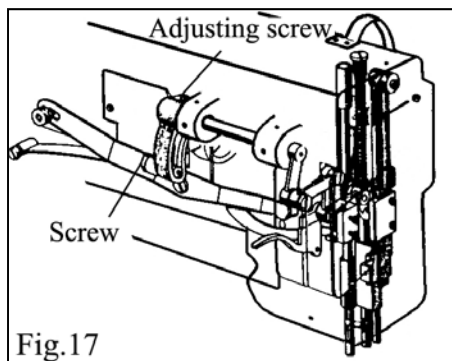
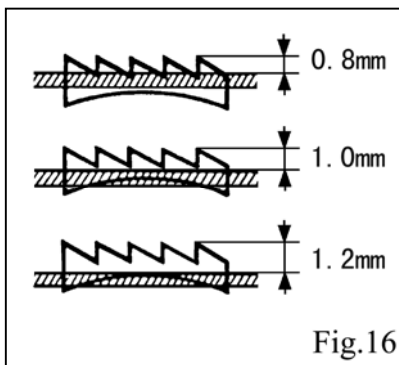

14. ADJUSTMENT OF THE VERTICAL STROKE WALK FOOT AND VIBRATING FOOT(Fig.17)

When the material with large elasticity is sewn, or when thickness of material changes, the vertical stroke of the presser feet should be adjusted as follows:

- (1) Loosen the special screw.
- (2) The vertical strokes of presser feet become minimum when the crank rod is moved downward and set.
- (3) The vertical strokes of presser feet become maximum when the crank rod is moved upward and set.
- (4) After the adjustment, tighten the special nut.

Note: The vertical strokes of presser feet can be adjusted within a range from 2mm to 6mm.

15. TIMING BETWEEN THE NEEDLE AND HOOK(Fig.18, Fig.19, Fig.20)

- (1) Set the stitch length to "0" on the feed setting dial.

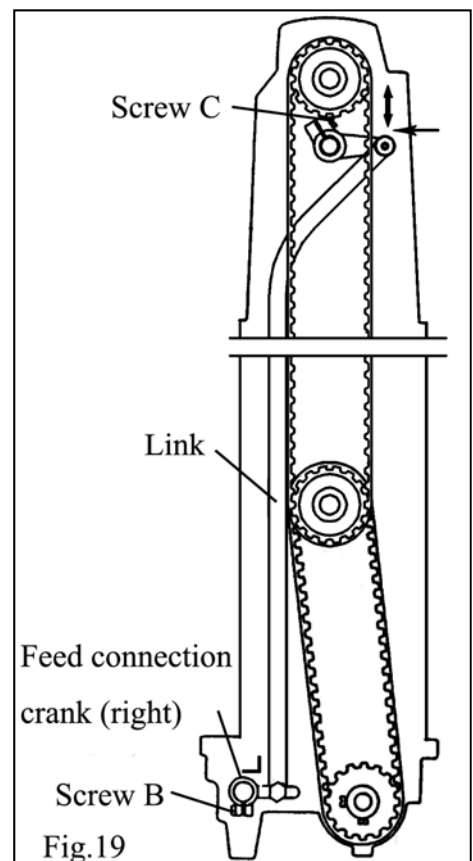

- (2) Lean the machine head backward.
- (3) Loosen the feed lifting rock shaft crank set screw A and B.
- (4) Set the needle at the lowest position.
- (5) Adjust the distance between presser bar and vibration bar to 8mm and temporarily tighten the feed lifting rock shaft crank set screw A and B.
- (6) Check the right feed lifting rock shaft crank is connected with the link at right angle, as shown in Fig.19.
- (7) If the connection is not at right angle, remove the back cover, loosen screw C.
- (8) And regulate the right angle.
- (9) After the completion of adjustment, fully tighten the screw A, B and C.

Note: At the same time make sure that the position between the needle and the feed dog.

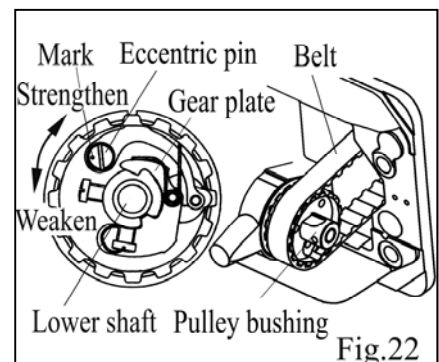
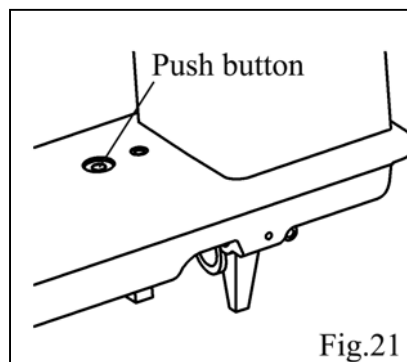
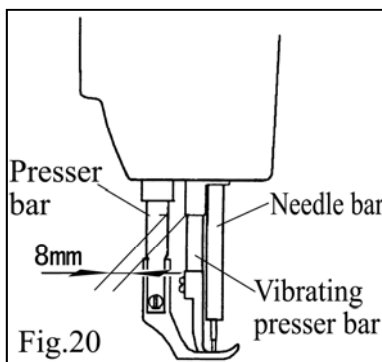

16. SAFETY CLUTCH DEVICE (Fig.21, Fig.22)

Safety clutch device is installed to prevent the hook and belt from damage in case the thread is caught into the hook when the machine is loaded abnormally during operation.

(1) Function of safety clutch

- a. When the safety clutch operates, the belt pulley will be unloaded, the lower shaft will stop. Only the arm shaft operates. The machine stops operation.
- b. Clean the thread thoroughly which is caught into the hook.
- c. Turn the belt bushing by hand, check the lower shaft rotates lightly. Then set the clutch device in the starting position.

(2) Set the safety clutch

a. While pressing down the push button on the bed by left hand, turn the pulley slowly by right hand away from you as shown in Fig.21.

b. When the belt pulley stopped by the gear plate, then turn the pulley more firmly.

c. Release the push button, the safety clutch device is set.

(3) Force applied to the safety clutch

a. The force applied to the safety clutch is the smallest when the mark on the eccentric pin faces the center of the lower shaft. The force proportionally increases as the mark faces the outside.

b. To adjust the force slide the belt, loosen the set screw, and turn eccentric pin.

c. After the adjustment, make sure to fasten the set screw.

A. ARM BED MECHANISM

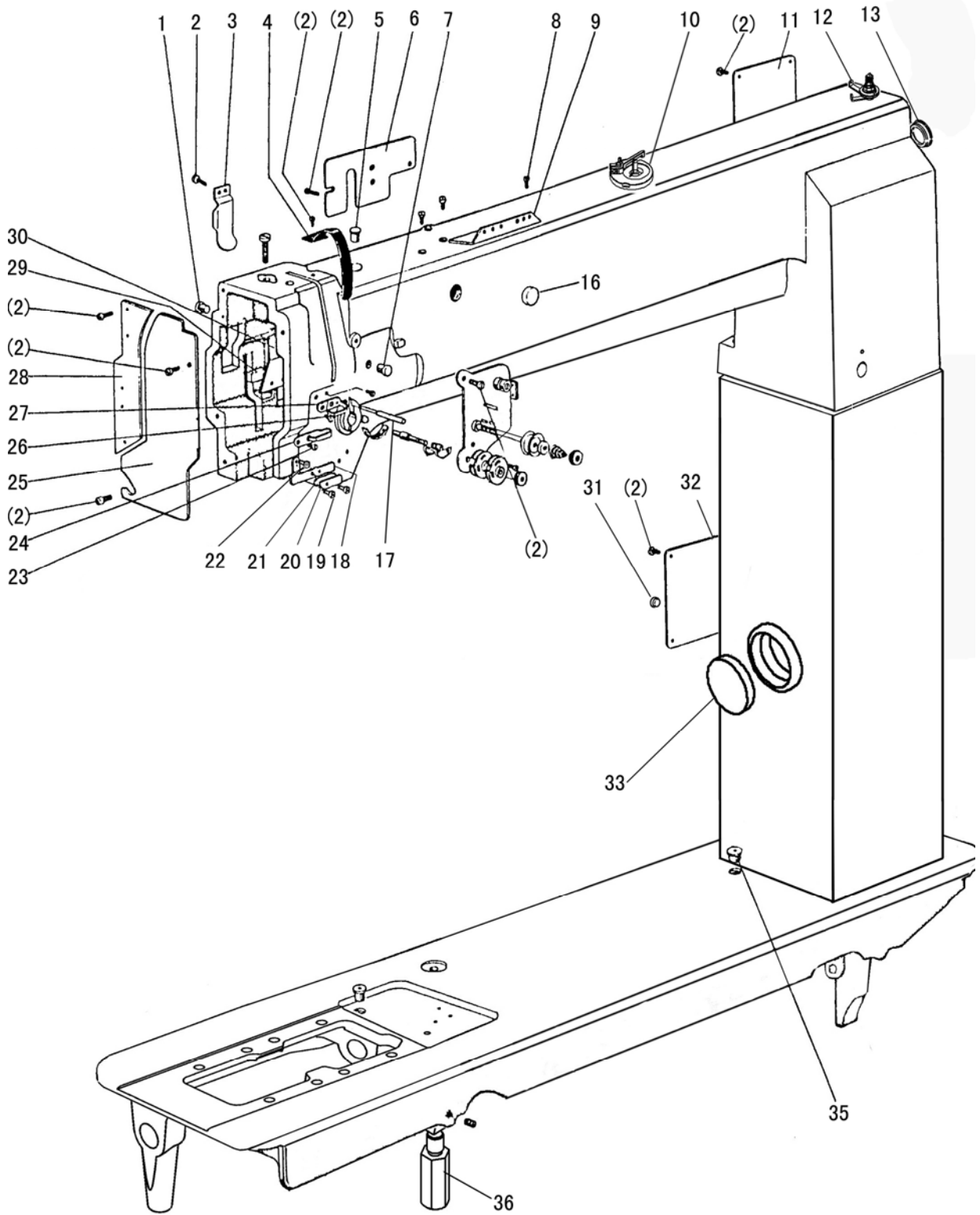

A.ARM BED MECHANISM

Fig. No.	Part No.	Description	GC24698-BRHL	GC24698-BLHL	Remarks
A01	HA300B2090	Rubber cap	2	2	
A02	HA300B2170	Screw	19	19	SM11/64(40)×8
A03	H4716B8001	Oil guard plate	1	1	
A04	H4717B8001	Thread take-up cover	1	1	
A05	H4715B8001	Rubber cap	1	1	Φ13
A06	H4718B8001	Arm side cover (left)	1	1	
A07	H2000B2010	Rubber cap	1	1	Φ13
A08	HA700B2060	Screw	2	2	SM11/64(40)×8
A09	H2400B2100	Thread guide	1	1	
A10	H7007D7101	Bobbin winder	1	1	
A11	HN41B38001	Arm side cover	1	1	
A12	H7014D7101	Thread tension complete	1	1	
A13	H0113B8001	Rubber cap	1	1	Φ36.5
A16	HA307B0673	Rubber cap	1	1	Φ18
A17	H7010E8001	Pin	1	1	
A18	H3212B0661	Thread guide	1	1	
A19	HA124B0713	Screw	2	2	SM3/32(56)×2.2
A20	H2407B2023	Felt	1	1	
A21	H2407B2022	Plate	1	1	
A22	H3200B2100	Screw	1	1	SM9/64(40)×6.5
A23	H3000D2160	Screw	1	1	SM9/64(40)×7
A24	H4726B8001	Thread guide	1	1	
A25	H4727B8001	Face plate	1	1	
A26	H2400B2080	Screw	2	2	SM3/16(28)×10
A27	H2400B2070	Thread guide	1	1	
A28	H4730B8001	Guide mounting plate	1	1	
A29	H2400B2060	Plate for oil guard	1	1	
A30	H3200B2060	Oil guard	1	1	
A31	HA300B2090	Rubber cap	1	1	
A32	H3207B0066	Arm side plate(right)	1	1	
A33	HN41B58001	Rubber cap	1	1	
A35	H2000M0090	Oil cup	3	3	
A36	HE956B8001	Bed bolt	1	1	

B. THREAD TENSION REGULATOR MECHANISM

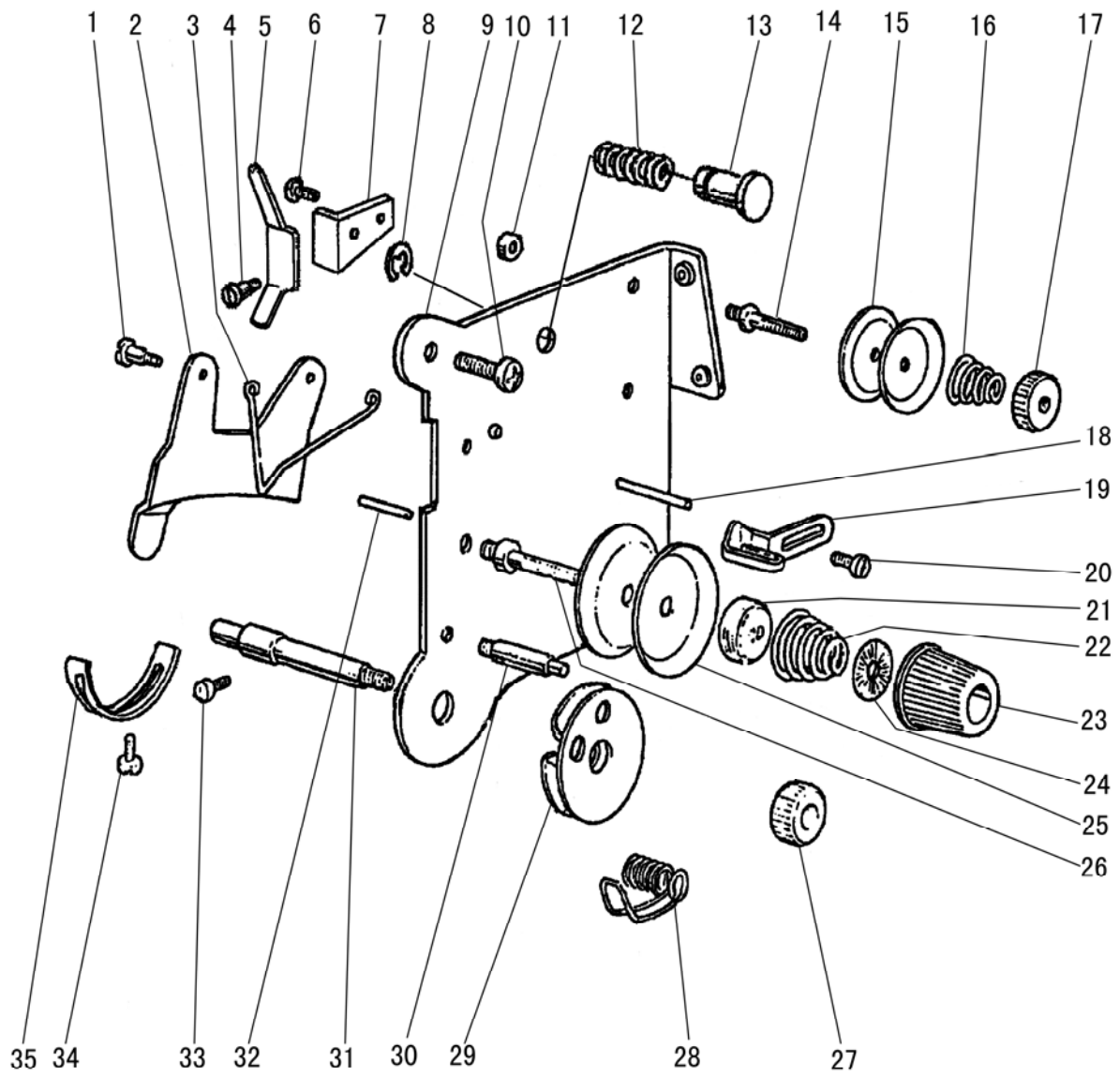

B.THREAD TENSION REGULATOR MECHANISM

Fig. No.	Part No.	Description	GC24698-BRHL	GC24698-BLHL	Remarks
B01	H3221B6811	Screw	2	2	SM9/64 (40) × 1.9
B02	H3221B3142	Tension releasing plate	1	1	
B03	H3221B6812	Tension releasing spring	1	1	
B04	H4705C8001	Screw	1	1	SM9/64 (40) × 2.9
B05	H4706C8001	Lever	1	1	
B06	HA7311C306	Screw	1	1	SM9/64 (40) × 5.5
B07	H4707C8001	Mounting plate	1	1	
B08	H007013050	E-type ring	1	1	
B09	H3221B6820	Mounting plate	1	1	
B10	HA300C2030	Screw	2	2	SM11/64 (40) × 8
B11	H3221B6810	Nut	1	1	SM11/64 (40)
B12	H4708C8001	Spring	1	1	
B13	H4709C8001	Push button	1	1	
B14	H3221B0683	Thread tension stud	1	1	SM11/64 (40) × 10
B15	HA112B0693	Thread tension disc	2	2	
B16	H3221B0684	Spring	1	1	
B17	HA710B0671	Thumb nut	1	1	SM11/64 (40)
B18	H3221B0682	Pin	2	2	
B19	H3306B0661	Thread guide	1	1	
B20	HA106B0676	Screw	1	1	SM9/64 (40) × 6
B21	HA310B0702	Tension releasing disc	1	1	
B22	H4710C8001	Spring	1	1	
B23	HA310B0701	Thumb nut	1	1	
B24	HA115B7010	Thumb nut revolution stopper	1	1	
B25	HA310B0705	Thread tension disc	2	2	
B26	H3221B0686	Thread tension stud	1	1	SM1/4 (40) × 13.5
B27	H32481B721	Thumb nut	1	1	SM1/4 (40)
B28	H4713C8001	Thread take-up spring	1	1	
B29	H32481BD21	Thread guide plate	1	1	
B30	H4804C8001	Screw	1	1	SM9/64 (40) × 2.9
B31	H4805C8001	Screw	1	1	SM1/4 (40) × 8.5
B32	H3221B6817	Pin	1	1	
B33	H3230K0751	Screw	1	1	SM11/64 (40) × 10
B34	H3200B2100	Screw	1	1	SM9/64 (40) × 6.5
B35	H3221B6819	Stopper	1	1	

C. ARM SHAFT&MIDDLE SHAFT MECHANISM

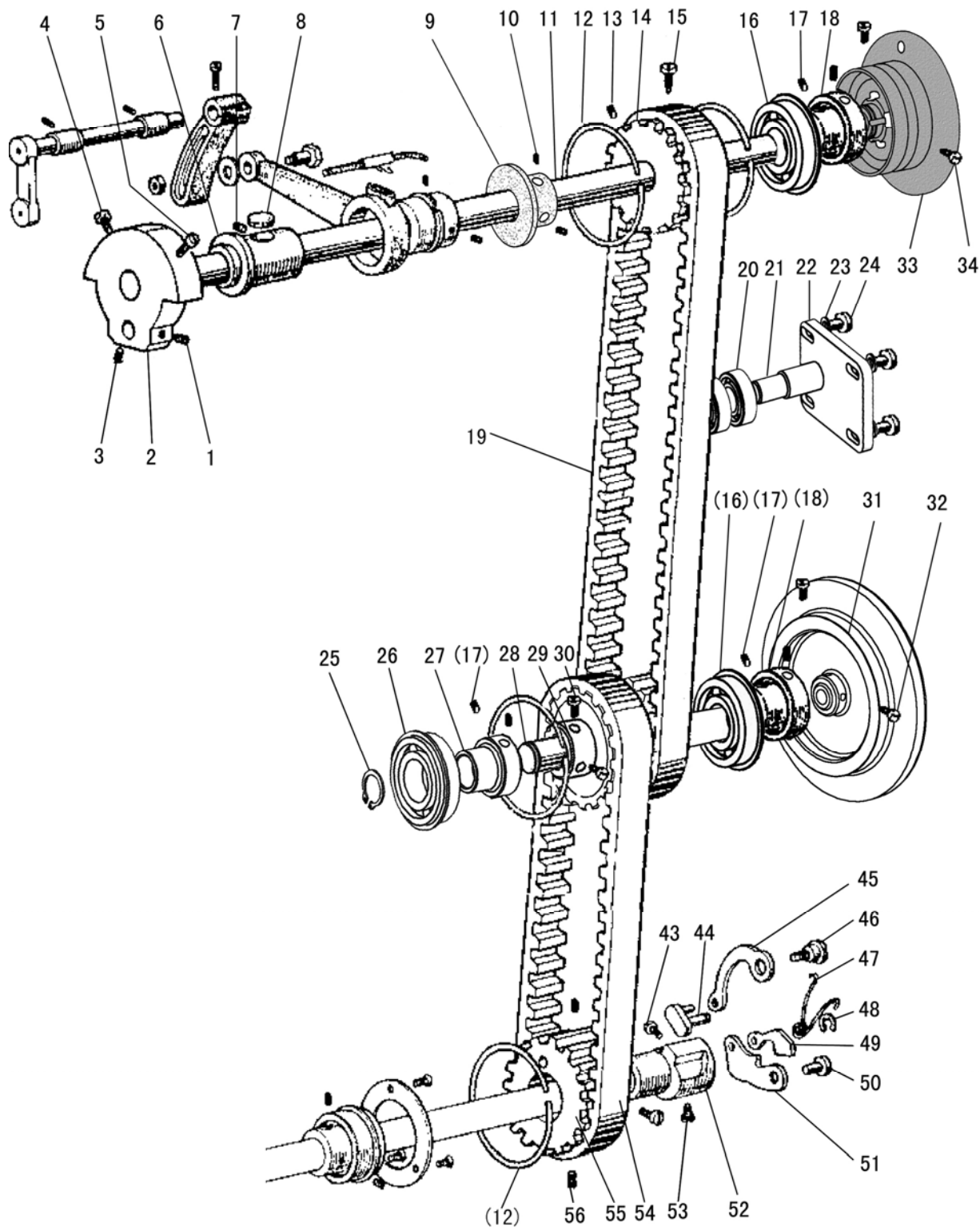

C.ARM SHAFT&MIDDLE SHAFT MECHANISM

Fig. No.	Part No.	Description	GC24698-BRHL	GC24698-BLHL	Remarks
C01	HA307C0662	Set screw	1	1	SM1/4 (40) × 6
C02	HA105D0662	Screw	1	1	SM1/4 (40) × 4
C03	H4706D8001	Crank	1	1	
C04	HA100C2060	Screw	1	1	SM9/32 (28) × 13
C05	HA100C2070	Screw	1	1	SM9/32 (28) × 10
C06	H32111B204	Arm shaft bushing(left)	1	1	
C07	H2405D0664	Screw	1	1	SM15/64 (28) × 14
C08	H32111B104	Felt	1	1	
C09	H7005D8001	Bushing	1	1	
C10	H5320C8001	Screw	2	2	SM15/64 (28) × 8
C11	HN40D48001	Arm shaft	1	1	
C12	H3205C0661	Spring flange	4	4	
C13	HA110D0672	Screw	1	1	SM15/64 (28) × 12
C14	H3205C1021	Belt pulley(upper)	1	1	
C15	HA100F2130	Screw	1	1	SM15/64 (28) × 14. 5
C16	H3205J0662	Bearing	2	2	6204ZZNR/5K
C17	HA113F0684	Screw	6	6	SM15/64 (28) × 8. 5
C18	H3205J0661	Bushing	2	2	
C19	H7104D8001	Belt(upper)	1	1	
C20	HE016C8001	Bearing	2	2	
C21	HN40D68001	Tension roll	1	1	
C22	H7107D8001	Mounting block	1	1	
C23	H005005060	Washer	4	4	
C24	H3208G0676	Screw	4	4	SM15/64 (28) × 14
C25	H007009150	Retaining ring C-type	1	1	
C26	H3208H0661	Bearing	1	1	6004ZZNR
C27	H5336C8001	Middle shaft busing	1	1	
C28	HN40D88001	Middle shaft	1	1	
C29	HN41D08001	Belt pulley(middle)	1	1	
C30	HA104F0654	Screw	2	2	SM15/64 (28) × 10
C31	HN41D38001	Pulley	1	1	
C32	H7206C8001	Screw	2	2	SM5/16 (24) × 19
C33	H4100C0020	Pulley	1	1	
C34	HA110D0672	Screw	2	2	SM15/64 (28) × 12
C43	HA104F0654	Screw	1	1	SM15/64 (28) × 10
C44	H4715D8001	Pin	1	1	
C45	H4713D8001	Link	1	1	
C46	H4714D8001	Pin	1	1	
C47	H4716D8001	Spring	1	1	
C48	H007013025	E-type ring	1	1	
C49	H4717D8001	Link	1	1	

C.ARM SHAFT&MIDDLE SHAFT MECHANISM

Fig. No.	Part No.	Description	GC24698-BRHL	GC24698-BLHL	Remarks
C50	H4718D8001	Pin	1	1	
C51	H4719D8001	Link	1	1	
C52	H4720D8001	Bushing	1	1	
C53	H4721D8001	Screw	1	1	SM15/64(28) × 10.5
C54	H3200C2030	Belt(lower)	1	1	
C55	H4722D8001	Belt pulley(lower)	1	1	
C56	H4723D8001	Screw	2	2	SM15/64(28) × 4.5

D.PRESSER FOOT MECHANISM

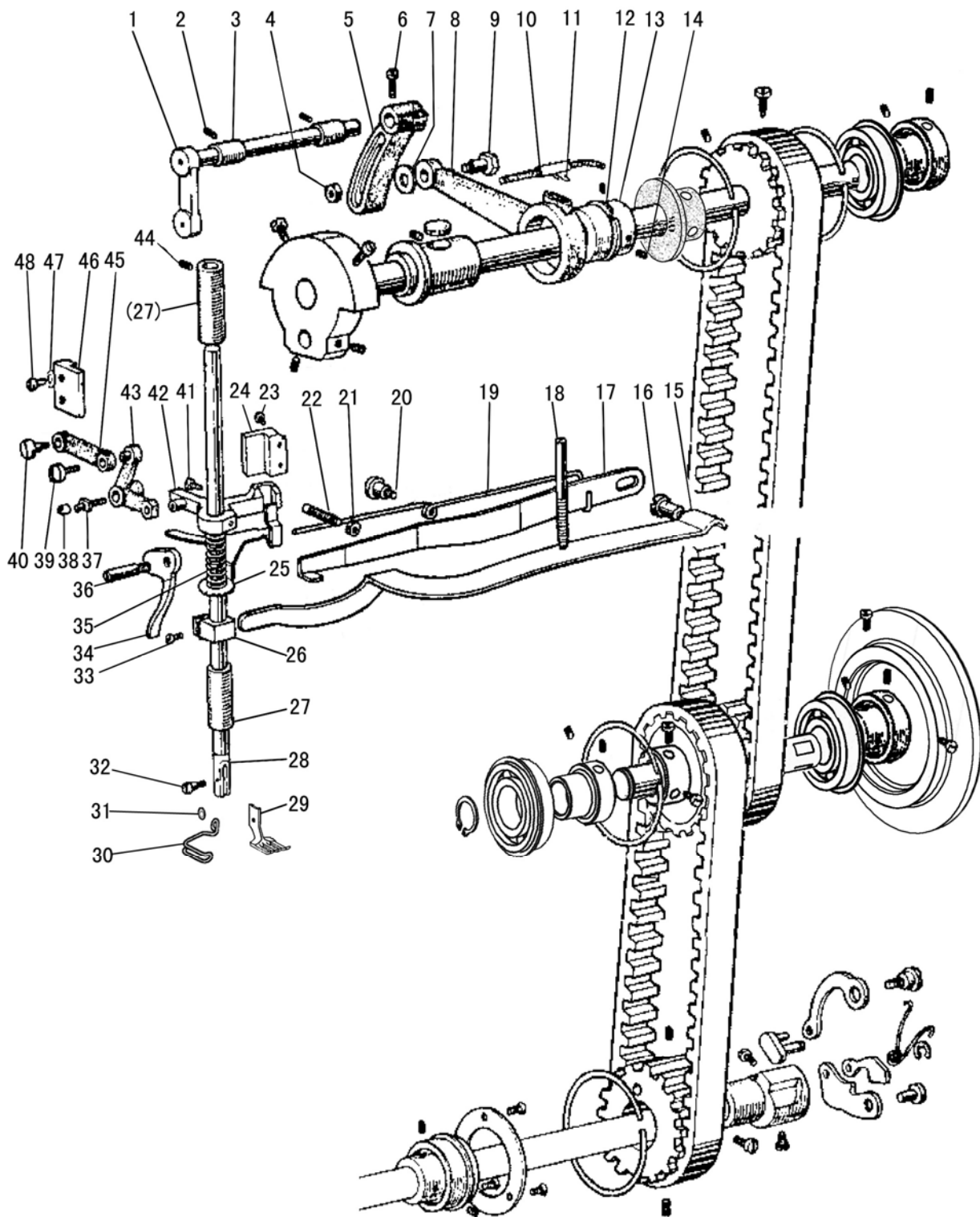

D.PRESSER FOOT MECHANISM

Fig. No.	Part No.	Description	GC24698-BRHL	GC24698-BLHL	Remarks
D01	H4705E8001	Feed lifting rock shaft	1	1	
D02	H4706E8001	Set screw	2	2	SM1/4 (24) × 7
D03	H4707E8001	Bushing	2	2	
D04	H0030580608	Nut	1	1	M6 × 0. 75
D05	H4709E8001	Crank	1	1	
D06	H3115F0671	Screw	1	1	SM1/4 (28) × 16
D07	H2013J0065	Washer	1	1	
D08	H2014J0066	Connecting rod	1	1	
D09	H2000J2100	Screw	1	1	M6 × 0. 75
D10	H4713E8001	Oil wick	1	1	
D11	H20111C106	Holder	1	1	
D12	H007009250	C-type ring	1	1	
D13	H4714E8001	Eccentric	1	1	
D14	HA307C0662	Screw	2	2	SM1/4 (40) × 6
D15	H4730E8001	Lever spring	1	1	
D16	H3100G2170	Screw	1	1	SM1/4 (24) × 10. 5
D17	H4728E8001	Knee lifting lever	1	1	
D18	H4729E8001	Screw	1	1	SM15/64 (28) × 41
D19	H4727E8001	Twist spring	1	1	
D20	H3100G2130	Screw	1	1	SM1/4 (24) × 7
D21	H4726E8001	Nut	1	1	SM1/4 (24)
D22	H4725E8001	Screw	1	1	SM1/4 (24) × 19
D23	HA111G0683	Screw	2	2	SM11/64 (40) × 12
D24	H4723E8001	Guide	1	1	
D25	H4768E8001	Thread releasing plate	1	1	
D26	H4746E8001	Spring bracket	1	1	
D27	H4744E8001	Bushing	2	2	
D28	H4754E8001	Presser bar	1	1	
D29	HN40E57101	Lifting presser foot	1	1	
D30	HE204I8001	Finger guard	1	1	
D31	HE044J8001	Washer	1	1	
D32	H3200E2020	Screw	1	1	SM1/8 (44) × 4
D33	H2404I0034	Screw	1	1	SM9/64 (40) × 8. 5
D34	H4748E8001	Lift lever	1	1	
D35	H4767E8001	Spring	1	1	
D36	H4749E8001	Screw	1	1	SM11/64 (40) × 8. 5
D37	H2004J0655	Screw	1	1	
D38	H4717E8001	Roller	1	1	
D39	H4718E8001	Screw	1	1	SM11/64 (32) × 6
D40	H2004J0662	Screw	1	1	SM1/4 (40) × 5
D41	H4753E8001	Screw	1	1	SM11/64 (40) × 17. 5

D.PRESSER FOOT MECHANISM

Fig. No.	Part No.	Description	GC24698-BRHL	GC24698-BLHL	Remarks
D42	H4752E8001	Bracket	1	1	
D43	H4715E8001	Bell crank	1	1	
D44	H4708D8001	Screw	2	2	SM1/4 (24) × 13
D45	H4719E8001	Link	1	1	
D46	H4721E8001	Bell crank guide	1	1	
D47	H4722E8001	Washer	2	2	
D48	HA100E2150	Screw	2	2	SM11/64 (40) × 10

E.NEEDLE BAR THREAD TAKE-UP MECHANISM

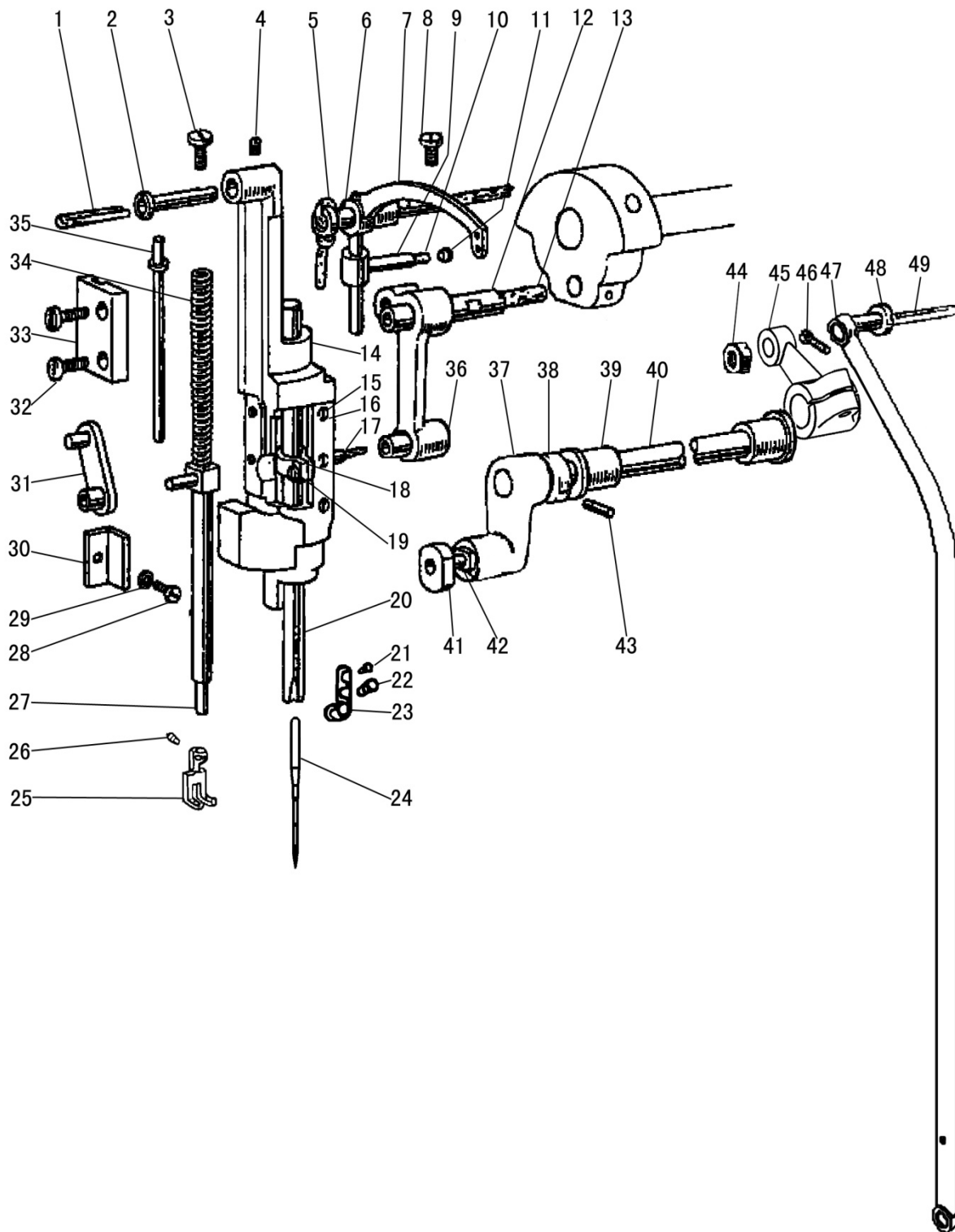

E.NEEDLE BAR THREAD TAKE-UP MECHANISM

Fig. No.	Part No.	Description	GC24698-BRHL	GC24698-BLHL	Remarks
E01	H2405D1122	Oil wick	1	1	
E02	H4706F8001	Needle bar guide bracket stud	1	1	
E03	H4707F8001	Screw	1	1	SM5/16 (28) × 10. 4
E04	HA100C2020	Screw	1	1	SM15/64 (28) × 10
E05	H2405D1122	Oil wick	1	1	
E06	H2405D1121	Thread take-up lever support stud	1	1	
E07	H4712F8001	Thread take-up lever	1	1	
E08	HA110D0672	Screw	1	1	SM15/64 (28) × 12
E09	H2405D1112	Thread take-up slide brock	1	1	
E10	H24211D405	Oil wick	1	1	
E11	H24211D305	Plug	1	1	
E12	H2405D0662	Needle bar crank pin	1	1	
E13	H4716F8001	Oil wick	1	1	
E14	H4719F8001	Needle bar guide bracket	1	1	
E15	H32111D304	Screw	6	6	SM3/32 (56) × 4
E16	H4721F8001	Washer	2	2	1. 4
E17	H3204D6513	Felt	1	1	
E18	H4722F8001	Needle bar holder	1	1	
E19	H32111D604	Screw	1	1	SM9/64 (40) × 8. 5
E20	H4806F8001	Needle bar	1	1	
E21	H3129F0691	Screw	1	1	SM3/32 (56) × 3
E22	HA100C2170	Screw	1	1	SM1/8 (44) × 4. 5
E23	H3129F0693	Thread guide	1	1	
E24		Needle	1	1	DP × 17-23
E25	H4807F8002	Vibrating presser foot	1	1	
E26	HA700F2100	Screw	1	1	SM11/64 (40) × 7
E27	H4725F8001	Vibrating presser bar	1	1	
E28	H3400C2020	Screw	1	1	SM11/64 (40) × 12
E29	H3400C2030	Washer	1	1	
E30	H3400C2010	Needle bar guide	1	1	
E31	H4726F8001	Vibrating presser bar link	1	1	
E32	H4753E8001	Screw	2	2	SM11/64 (40) × 17. 5
E33	H4728F8001	vibrating presser bar guide	1	1	
E34	H4729F8001	Spring	1	1	
E35	H4730F8001	Vibrating presser spring guide	1	1	
E36	H4717F8001	Connecting link	1	1	
E37	H3406C0672	Needle bar vibrating crank(left)	1	1	
E38	H4734F8001	Washer	1	1	
E39	H3204B0652	Needle bar vibrating shaft bushing	2	2	
E40	H7004F8001	Needle bar vibrating shaft	1	1	
E41	H4759F8001	Slide block	1	1	

E.NEEDLE BAR THREAD TAKE-UP MECHANISM

Fig. No.	Part No.	Description	GC24698-BRHL	GC24698-BLHL	Remarks
E42	H3406C0671	Crank pin	1	1	SM15/64 (28) × 10
E43	H602040240	Taper	1	1	
E44	H7107F8001	Nut	1	1	SM5/16 (24)
E45	H7104F8001	Needle bar vibrating crank(right)	1	1	
E46	H2012N0652	Screw	1	1	SM1/4 (44) × 16
E47	HN40F48001	Link	1	1	
E48	H7108F8001	Screw	1	1	SM5/16 (24) × 6
E49	H32311D406	Oil wick	1	1	

F.STITCH REGULATOR MECHANISM

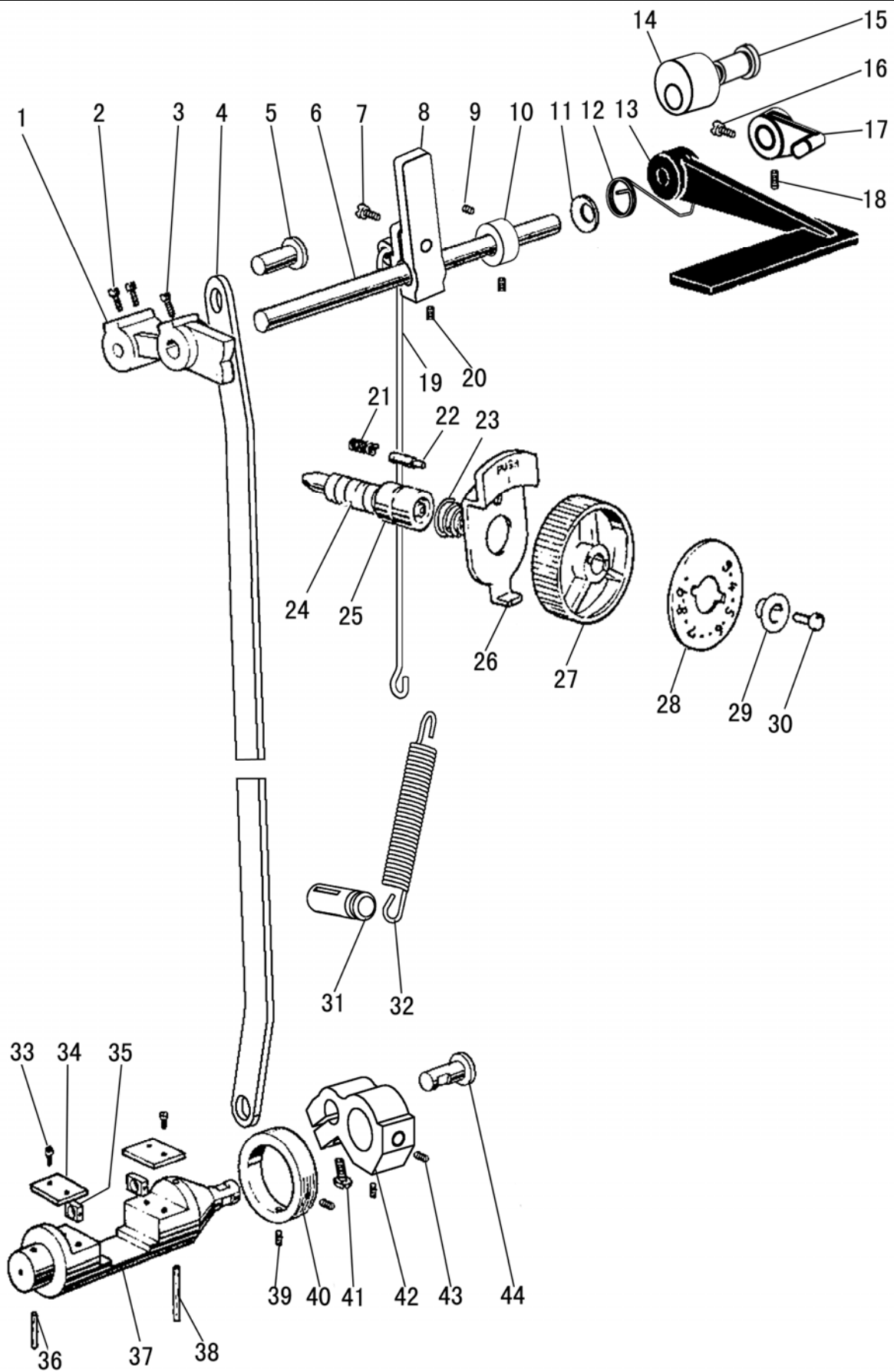

F.STITCH REGULATOR MECHANISM

Fig. No.	Part No.	Description	GC24698-BRHL	GC24698-BLHL	Remarks
F01	H4706G8001	Feed regulator	1	1	
F02	HA113F0684	Screw	2	2	SM15/64 (28) × 8. 5
F03	H3200F2020	Screw	1	1	SM15/64 (28) × 12
F04	HN40G48001	Link	1	1	
F05	HA100G2070	Eccentric shaft	1	1	
F06	HN40G58001	Reverse stitch shaft	1	1	
F07	HA800F2020	Screw	1	1	SM15/64 (28) × 12
F08	HF30G58001	Reverse stitch crank	1	1	
F09	H431050050	Screw	2	2	
F10	H8841B8001	Collar	1	1	
F11	HA100F2110	Washer	1	1	
F12	H4939L8001	Spring	1	1	
F13	H4906G8001	Feed reversing lever	1	1	
F14	H4938L8001	Rubber block	1	1	
F15	H4937L8001	Screw	1	1	
F16	HA113F0684	Screw	1	1	SM15/64 (28) × 8. 5
F17	H4936L8001	Block	1	1	
F18	HA3411D308	Screw	1	1	SM15/64 (28) × 7
F19	H7105G8001	Link	1	1	
F20	H3207F0672	Screw	1	1	SM11/64 (40) × 8. 5
F21	H3200F2110	Spring	1	1	
F22	HA700F2030	Stoper pin	1	1	
F23	HA720F0687	Spring	1	1	
F24	HA109F0671	Screw	1	1	
F25	HA109F0674	Ring	1	1	
F26	HA720F0683	Plate	1	1	
F27	HA7421F120	Dial	1	1	
F28	H4809G8001	Stitch length indicating plate	1	1	
F29	HA720F0685	Bushing	1	1	
F30	HA720F0686	Screw	1	1	SM3/16 (28) × 12
F31	H6510H8001	Pin	1	1	
F32	H4710G8001	Spring	1	1	
F33	HA300C2030	Screw	4	4	SM11/64 (40) × 8
F34	H4723G8001	Guide plate	2	2	
F35	H4722G8001	Square block	2	2	
F36	H4721G8001	Felt(short)	1	1	
F37	H4720G8001	Reverse block	1	1	
F38	H4719G8001	Felt(long)	1	1	
F39	HA3411D308	Screw	2	2	SM15/64 (28) × 7
F40	H4716G8001	Collar	1	1	
F41	H415050140	Screw	1	1	
F42	H4714G8001	Reverse sewing crank	1	1	
F43	H428050060	Screw	2	2	
F44	H3206F0662	Pin	1	1	

G.LOWER SHAFT&FEEDING SHAFT MECHANISM

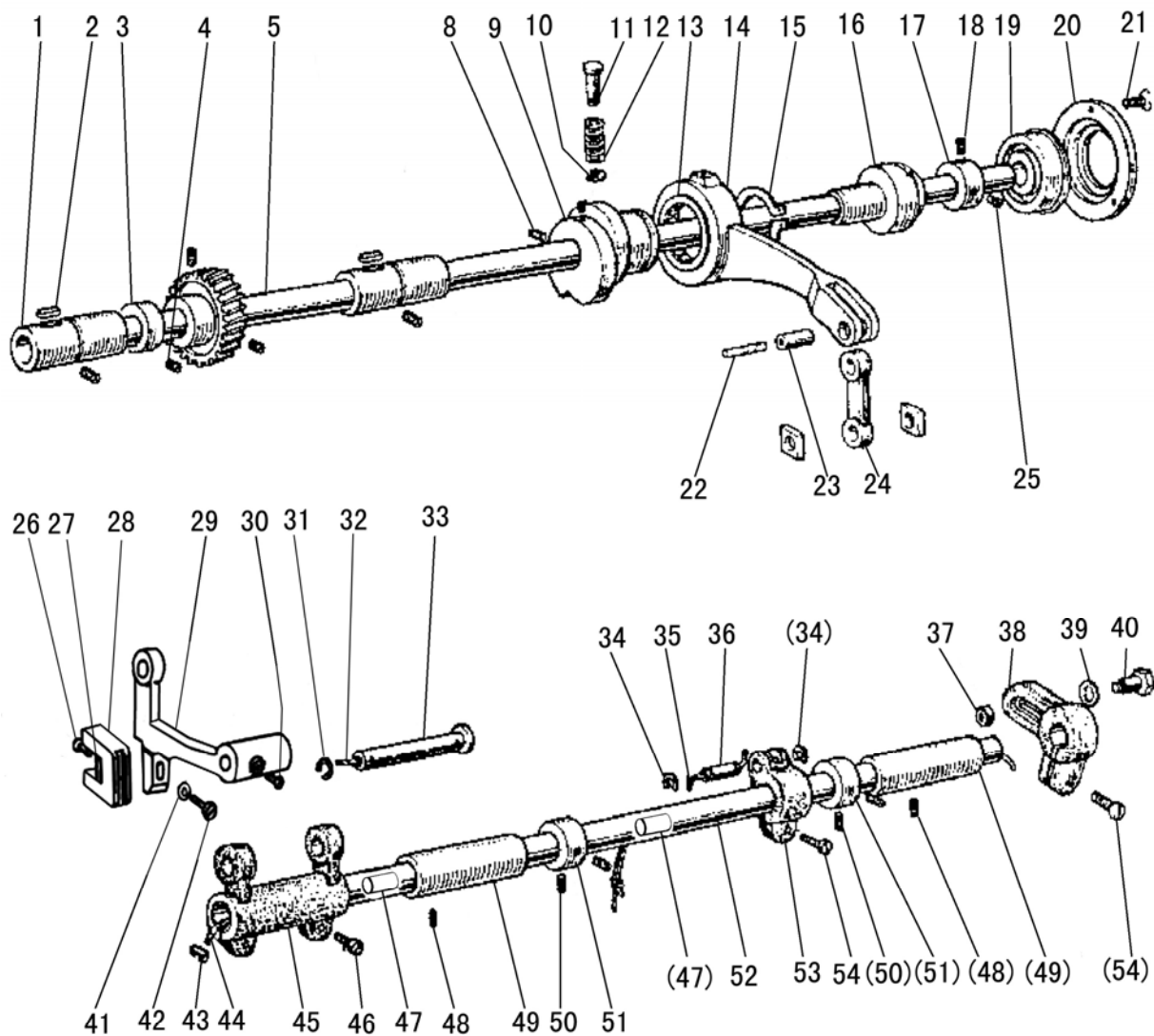

G.LOWER SHAFT&FEEDING SHAFT MECHANISM

Fig. No.	Part No.	Description	GC24698-BRHL	GC24698-BLHL	Remarks
G01	H4706H8001	Lower shaft bushing (left)	2	2	
G02	H4707H8001	Oil wick	2	2	
G03	HF60H68001	Feed eccentric cam	1	1	
G04	H3205H0654	Screw	1	1	SM1/4 (40) × 5
G05	H7004H8001	Lower shaft	1	1	
G08	H2405D0664	Screw	1	1	SM15/64 (28) × 14
G09	H4717H8001	Feed eccentric	1	1	
G10	H007013050	E-type stop ring	1	1	
G11	H4715H8001	Push button	1	1	
G12	H4714H8001	Spring	1	1	
G13	H4719H8001	Needle bearing	1	1	NTN 7E-HMK 2616D
G14	H4718H8001	Feed connecting rod	1	1	
G15	H007009260	C-type stop ring	1	1	
G16	H7006H7101	Lower shaft bushing complete (middle)	1	1	
G17	H4725H8001	Bushing	1	1	
G18	HA105D0662	Screw	1	1	SM1/4 (40) × 4
G19	H4726H8001	Ball bearing	1	1	NTN 6203Z
G20	H4727H8001	Bearing holder	1	1	
G21	HA7311C306	Screw	3	3	SM9/64 (40) × 5. 5
G22	H4720H8001	Oil wick	1	1	
G23	H4721H8001	Shaft	1	1	
G24	H4737H8001	Link	1	1	
G25	H3205H0654	Screw	1	1	SM1/4 (40) × 5
G26	H4961K8001	Screw	1	1	SM1/8 (44) × 4. 5
G27	H3205H0652	Felt	1	1	
G28	H4743H8001	Feed bar forked connection	1	1	
G29	H6305G8001	Feed bar	1	1	
G30	H429050050	Screw	1	1	
G31	H007009070	C-type stop ring	1	1	
G32	H3205G0662	Oil wick	1	1	
G33	H32243G205	Feed bar shaft	1	1	
G34	H007013050	E-type stop ring	2	2	
G35	H4739H8001	Oil wick	1	1	
G36	H4738H8001	Pin	1	1	
G37	H0030580608	Nut	1	1	M6 × 0. 75
G38	H4731H8001	Feed connection crank (right)	1	1	
G39	H4728H8001	Washer	1	1	
G40	H4729H8001	Screw	1	1	M6 × 0. 75
G41	H2013J0065	Washer	1	1	
G42	H3200H2040	Screw	1	1	SM15/64 (28) × 17
G43	H3200G2030	Clip	1	1	

G.LOWER SHAFT&FEEDING SHAFT MECHANISM

Fig. No.	Part No.	Description	GC24698-BRHL	GC24698-BLHL	Remarks
G44	H3204G0031	Oil wick	1	1	
G45	H3205G1032	Feed connection crank (left)	1	1	
G46	HA104G0012	Screw	2	2	SM3/16 (28) × 12
G47	H4740H8001	Felt	2	2	
G48	H4708D8001	Screw	2	2	SM1/4 (24) × 13
G49	HA100G2120	Feed rock shaft bushing	2	2	
G50	HA105D0662	Screw	4	4	SM1/4 (40) × 4
G51	HA108G0661	Collar	2	2	
G52	H7005H8001	Feed rock shaft	1	1	
G53	H4736H8001	Feed connection crank (middle)	1	1	
G54	H2012N0652	Screw	2	2	SM1/4 (44) × 16

H.HOOK SADDLE MECHANISM

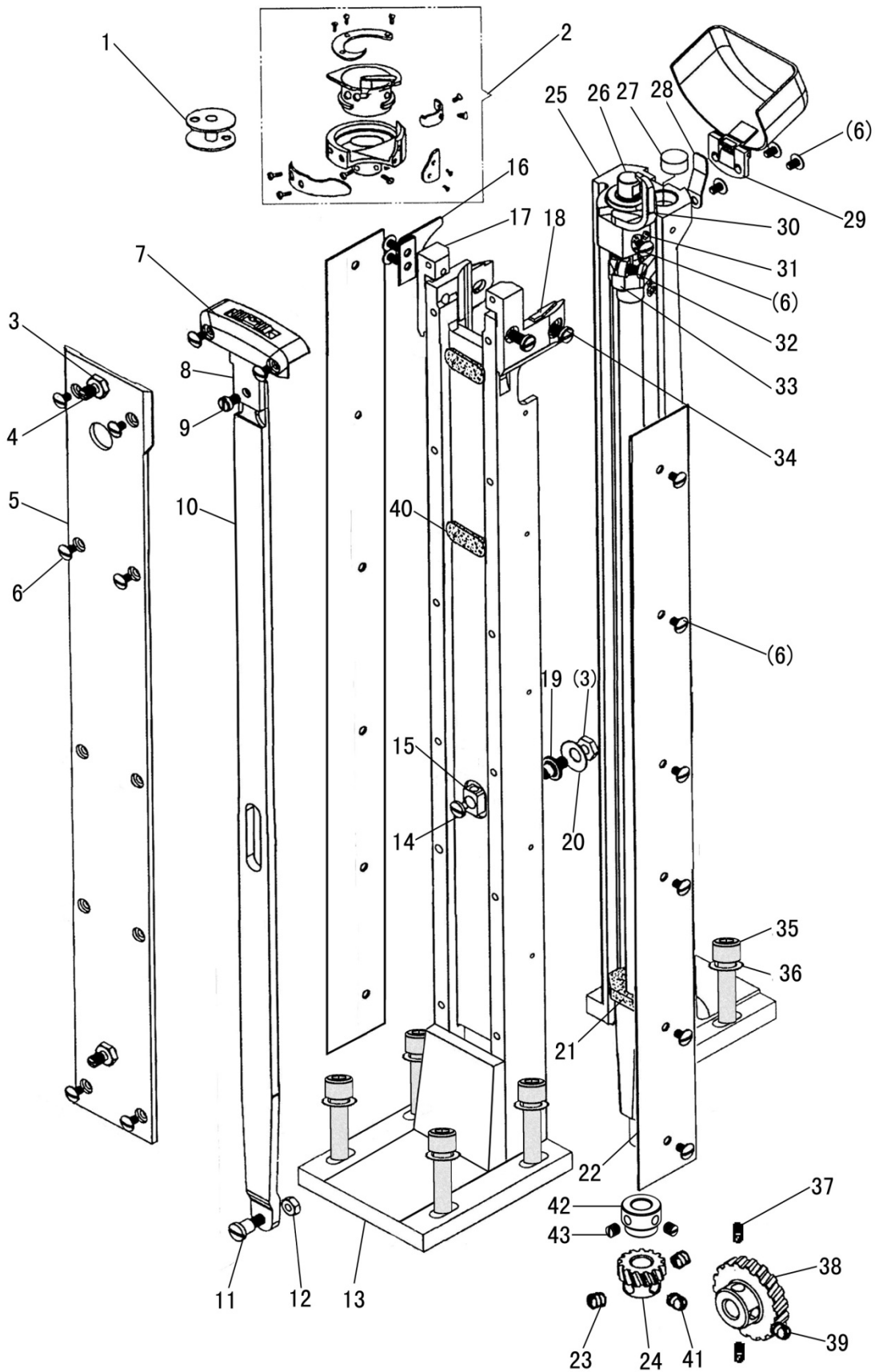

H.HOOK SADDLE MECHANISM

Fig. No.	Part No.	Description	GC24698-BRHL	GC24698-BLHL	Remarks
H01	HD806I8001	Bobbin	1	1	
H02	HD804I7101	Hook	1	1	KRT8-LPS
H03	HE021B8001	Nut	3	3	
H04	HE028E8001	Screw	2	2	SM7/32(32) × 7
H05	HN41I58001	Plate	1	1	
H06	HE517J8001	Screw	26	26	SM9/64(40) × 5.5
H07	HN41I38001	Needle plate	1	1	
H08	HN41I18001	Feed dog	1		
H08	HFI2068001	Feed dog		1	
H09	HE012E8001	Screw	1	1	SM11/64(32) × 6.5
H10	HN41I28001	Feed bar	1	1	
H11	H0204I8001	Screw	1	1	SM3/16(32) × 7.5
H12	HE540J8001	Nut	1	1	
H13	HN40I98001	Feed bar set bracket	1	1	
H14	HE123I8001	Screw	1	1	SM1/8(44) × 4
H15	HE535J8001	Slide block	1	1	
H16	HE406I8001	Plate	1	1	
H17	HE405I8001	Hook support bracket(back)	1	1	
H18	HE404I8001	Hook support bracket(front)	1	1	
H19	HE536J8001	Screw	1	1	
H20	HE045D8001	Washer	1	1	
H21	HE514J8001	Felt	1	1	
H22	HN41I68001	Side plate	2	2	
H23	H4705I8001	Gear(small)	1	1	
H24	HA105D0662	Screw	2	2	SM1/4(40) × 4
H25	HN40I48001	Hook saddle	1	1	
H26	HN40I77101	Hook shaft	1	1	
H27	HE511J8001	Felt	1	1	
H28	HE524J8001	Spring plate	1	1	
H29	HE518J7101	Slide plate	1	1	
H30	HE512J8001	Opener	1	1	
H31	HE516J8001	Oil wick	1	1	
H32	HE022K8001	Screw	1	1	SM11/64(32) × 9
H33	HE513J8001	Crank	1	1	
H34	HE543J8001	Screw	4	4	SM3/16(32) × 9.5
H35	H2400I2120	Screw	6	6	SM5/16(24) × 18
H36	H005001080	Washer	6	6	
H37	H4707I8001	Screw	1	1	SM1/4(40) × 6.5
H38	H4706I8001	Gear(big)	1	1	
H39	HA307C0662	Screw	2	2	SM1/4(40) × 6
H40	HE410I8001	Felt	2	2	
H41	H3205H0654	Screw	1	1	SM1/4(40) × 5
H42	HE548J8001	Collar	1	1	
H43	HA3411D308	Screw	2	2	SM15/64(28) × 7

I.OIL LUBRICATION MECHANISM

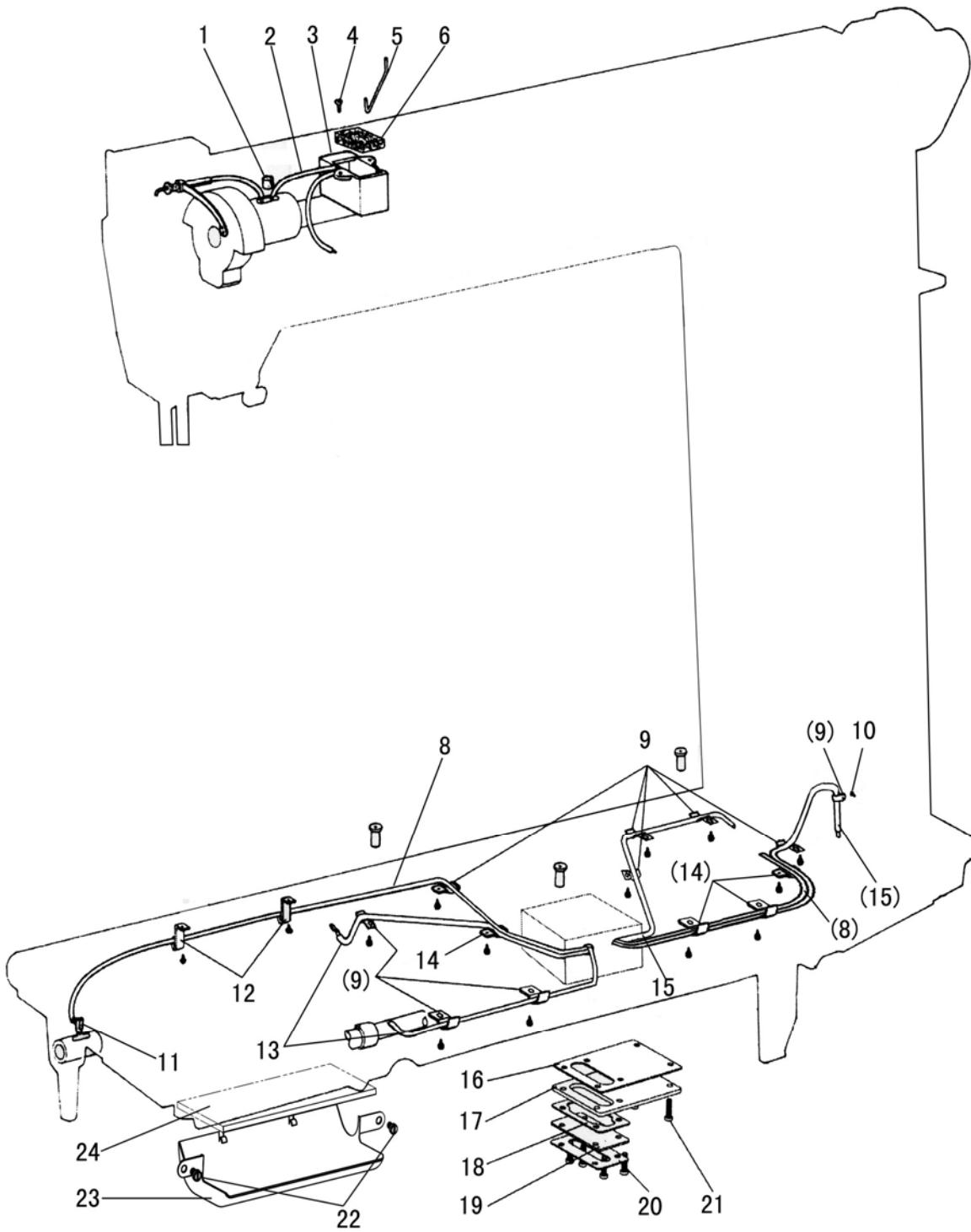

I.OIL LUBRICATION MECHANISM

Fig. No.	Part No.	Description	GC24698-BRHL	GC24698-BLHL	Remarks
I01	H32175B304	Felt	1	1	
I02	H4705J7101	Oil pipe complete	1	1	
I03	H3204K0011	Oil reservoir complete	1	1	
I04	H411040160	Screw	2	2	
I05	H4707J8001	Holder	1	1	
I06	H7005J8001	Felt	1	1	
I08	H7004J7101	Oil pipe complete	2	2	
I09	H32311D606	Holder	9	9	
I10	HA106B0676	Screw	15	15	SM9/64(40)×7
I11	H3200K0180	Oil wick $\Phi 2.5 \times 35$	3	3	
I12	H3200K0160	Holder	2	2	
I13	H7010J7101	Oil pipe complete	2	2	
I14	H3200K0170	Holder	4	4	
I15	H7007J7101	Oil pipe complete	2	2	
I16	H7021J8001	Sealed cushion	1	1	
I17	H7020J8001	Pressing plate	1	1	
I18	H2000M0190	Sealed cushion	1	1	
I19	H2000M0180	The oil amount observes window	1	1	
I20	H2000M0200	Pressing plate	1	1	
I21	H3107G0661	Screw	6	6	SM11/64(40)×15
I22	H7330C8001	Screw	2	2	SM11/64(40)×6
I23	HE519M8001	Oil tank	1	1	
I24	HE520M8001	Felt	1	1	

J.ACCESSORIES

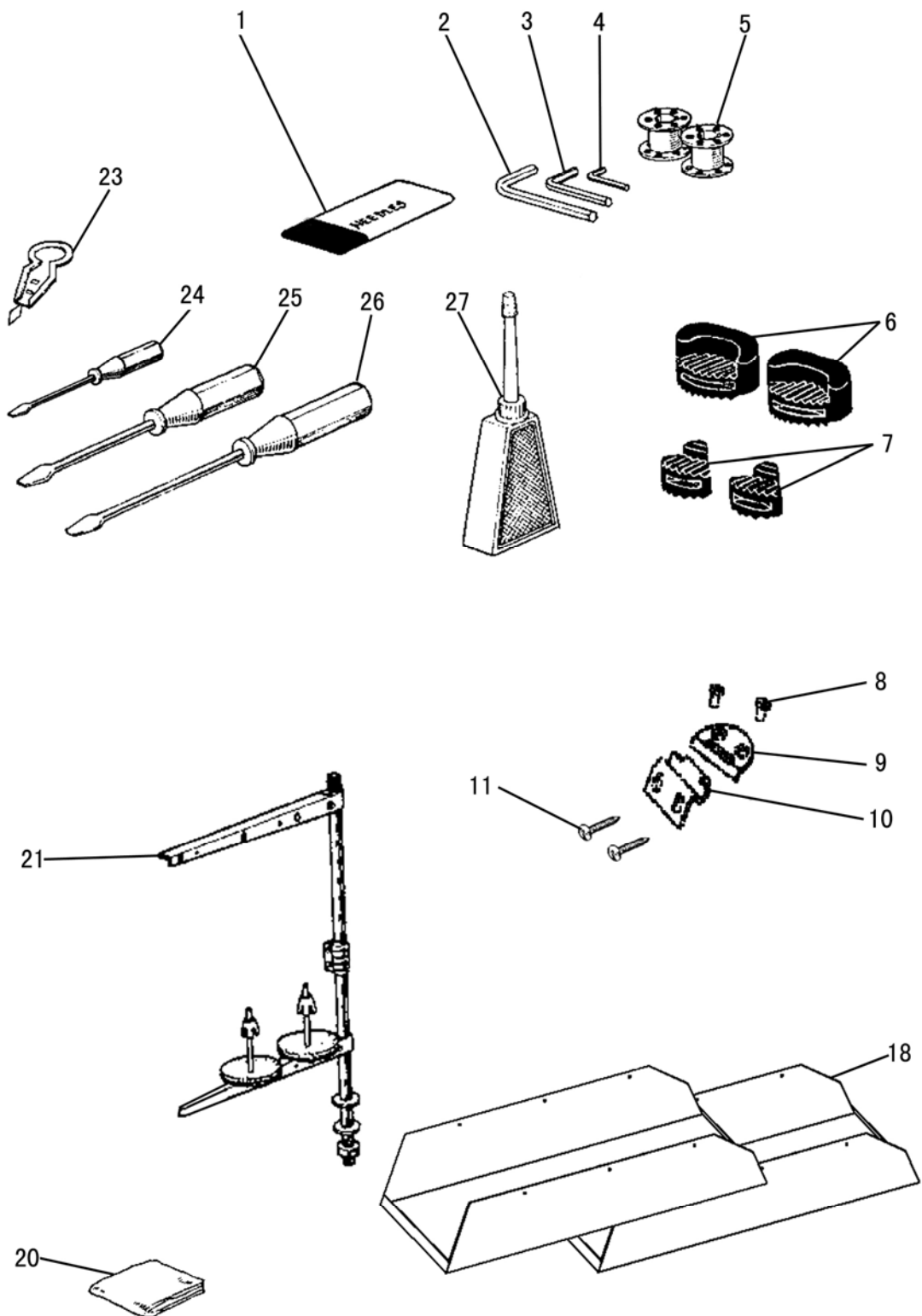

J.ACCESSORIES

Fig. No.	Part No.	Description	GC24698-BRHL	GC24698-BLHL	Remarks
J01		Needle	4	4	DP×17 23#
J02	HB01001025	Socket wrench	1	1	2.5mm
J03	HB01001030	Socket wrench	1	1	3mm
J04	HB01001015	Socket wrench	1	1	1.5mm
J05	HD806I8001	Bobbin	2	2	
J06	HF905L8001	Vibration preventing rubber	3	3	
J07	H200400066	Vibration preventing rubber	1	1	
J08	H2404K0656	Screw	4	4	
J09	H2404K0654	Hinge complete 1	2	2	
J10	H2404K0655	Hinge complete 2	2	2	
J11	H802080350	Screw	4	4	
J18	HN41K58001	Oil pan	2	2	
J20	H7009K8001	Machine cover	1	1	
J21	HA200J2070	Thread stand	1	1	
J23	H3207L0065	Thread a needle kit	1	1	
J24	HA300J2210	Screw driver (small)	1	1	
J25	HA300J2200	Screw driver (middle)	1	1	
J26	HA300J2070	Screw driver (large)	1	1	
J27	HF912L7101	Oiler	1	1	

K.TOUCH BACK AND FOOT LIFT MECHANISM

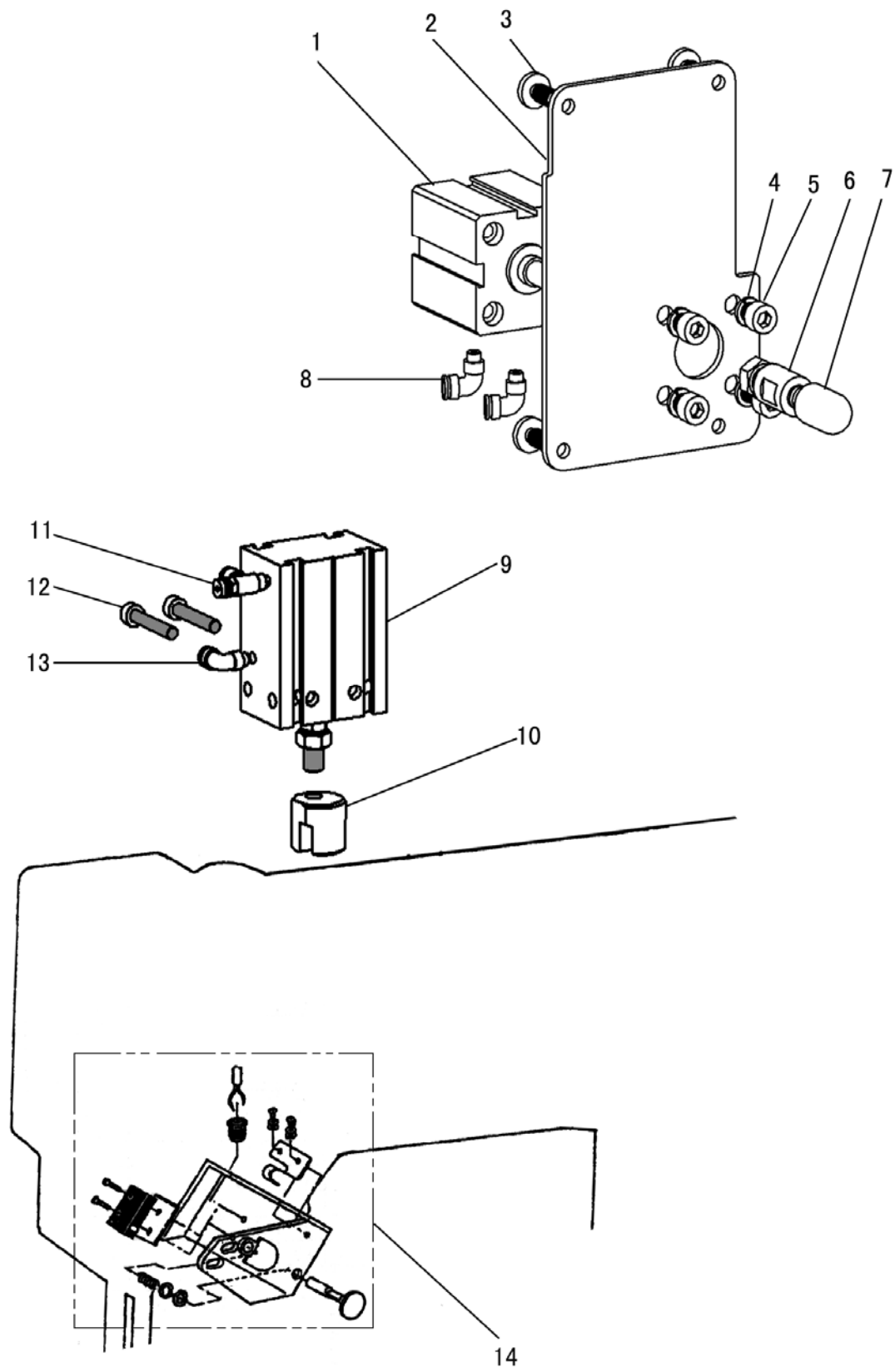

K.TOUCH BACK AND FOOT LIFT MECHANISM

Fig. No.	Part No.	Description	GC24698-BRHL	GC24698-BLHL	Remarks
K01	H4915G8001	Air cylinder	1	1	SDA25×25-B
K02	HN41B38001	Side plate	1	1	
K03	HA300B2170	Screw	4	4	SM11/64(40)×8
K04	H005008060	Spring washer	4	4	
K05	H415060200	Screw	4	4	
K06	H4914G8001	Pole	1	1	
K07	H4913G8001	Feeler	1	1	
K08	H4916G8001	Joint	2	2	Φ 6-M5, EPL6-M5
K09	H4905E8001	Air cylinder	1	1	MD25×25
K10	H4906E8001	Block	1	1	
K11	H0608N8001	Value	1	1	Φ 6-M5, ESL6-M5
K12	H415050300	Screw	2	2	
K13	H4916G8001	Joint	1	1	Φ 6-M5, EPL6-M5
K14	HN40L47101	Touch switch complete	1	1	

SHANGHAI BIAOZHUN HAILING SEWING MACHINERY CO., LTD.

ADD: NO.850 Shulin Road, Songjiang District Shanghai, P.R.China

Zip Code: 201612

Overseas Business: TEL: 86-21-64853303 FAX: 86-21-64854304

E-mail:sales@highlead.com.cn <http://www.highlead.com.cn>

The description covered in this manual is subject to change for improvement of the commodity without notice

2019.3. Printed